

**BE IT REMEMBERED** that the Board of Supervisors of Clay County, Mississippi, met at the Courthouse in West Point, MS, on the 28th day of July, 2016, at 9 00 a m , and present were Lynn Horton, Luke Lummus, R B Davis, President, Shelton Deanes, and Joe Chandler Also present were Amy G Berry, Chancery Clerk and Clerk to the Board, Bob Marshall, Board Attorney, and Eddie Scott, Sheriff of Clay County, when and where the following proceedings were as determined to wit,

NO \_\_\_\_\_

1

**IN THE MATTER OF ADOPTING AND AMENDING THE AGENDA FOR THE  
BOARD OF SUPERVISORS MEETING HELD ON JULY 28, 2016**

---

There came on this day for consideration the matter of adopting the agenda for the Board of Supervisors meeting held on July 28, 2016

It appears to this Board the following items listed below should be added to the agenda for further discussion and consideration by this Board, to-wit

- Eddie Scott, Sheriff, request to go into executive session regarding security issue
- Joe Chandler request to remove the item on the agenda to be discussed by him

After motion by Lynn Horton and second by Shelton Deanes this Board doth vote unanimously to adopt the agenda as presented and as amended by this Board as is attached hereto as Exhibit A

SO ORDERED this the 28h day of July, 2016



\_\_\_\_\_  
President



**Clay County Board of Supervisors  
Agenda for Meeting Held  
Thursday, July 28, 2016 at 9 00 a m**

- Call to Order
- Welcome and Prayer
- Adopt and Amend agenda
- Robert Calvert
  - SAP Road Program for West Point Industrial Road, Tibbee Road, Brand-Una Road, and Pheba South Road
  - SAP Road Program for Siloam Una Road
  - SAP FY2017 Bridge Inspection Program
  - Utility Permut for Old Waverly Golf Clun on Waverly Road
  - Utility Permut for Wayne Litwaller on Yokohama Boulevard

~~X~~ Zack Clair, Managing Editor for Commercial Dispatch

~~X~~ • Authorize and approve to spread on the minutes the BCAP monthly Reports for May and June 2016

~~X~~ Paige Lamkin

- Request to void or correct Homestead Exemption Applications as received from the MS Department of Revenue

~~X~~ Authority for Certain County Employees to Travel (See Attached)

~~X~~ • Authorize payment on Claim received from the MS Employment Department of Employment Security in the amount of \$1,465 38 for unemployment wages

- Authorize and approve the final intent of this Board to Transfer surplus funds in the amount of \$100,000 as advertised for (4) consecutive weeks from fund # 400, Sanitation to fund # 100, General County
- Authorize and accept Bids as received on Hay Lease Agreement running from July 28, 2016 thru January 2, 2017
- Authorize and approve the Constables Net Monthly Gross Fee Income for July 2016
- Authorize and approve to enter into an Equipment Sharing Agreement between Districts 1, 4, and 5 on the 2015 Tractor/Truck purchased in June 2016 for District 4
- Authorize and approve the Chancery Clerk and the President to execute lease purchase agreements on (2) pieces of equipment, pending attorney's approval
  - 2015 6x4 Freightliner Tractor/Truck Model 114SD, purchased from Empire Trucks at \$107,945 00 for Districts 1, 4, and 5
  - 2017 single axle Truck with a 7/8 yard dump bed from Empire Trucks at \$75,575 00 for District 3

- Bob Marshall, Board Attorney
    - Acquisition of Property behind the Clay County Detention Center
    - Justice Court Collection Contract with Pioneer Recovery Services, Inc
    - Authorization to file suit in Shaffer eminent domain case
  - Shelton Deanes
    - Authorize and accept the bid to do repairs on Moon Heard Road to be paid for by District 4 pending FEMA and MEMA reimbursement
    - Consider purchasing from Golden Triangle Mill Services @ Steel Dynamics
  - Joe Chandler
    - Authorize the purchase for District 5 for a 10' Flex Cutter from Winona Tractor & Equipment (lowest bid) for \$14,0000
- Request to go into closed session as allowed under Section 25-41-7 of the Miss Code of 1972, regarding potential litigation
- Public Hearing on the Board submitting a HOME Project Grant Application as advertised to be held at 10 00 a.m
  - Discuss Budget Hearing meeting times and dates beginning in August to prepare the 2016-2017 budget
  - Adjourn until Monday, August 1, 2016 at 9 00 a m

*Keep Session*

**Amendments**

*- To Remove J. Chandler off of agenda  
no equipment*

---



---



---

**The following Employees or Elected Officials have requested authority to travel for County Business**

- Harriett Bragg, MS Justice Court Clerks Convention, Sept 6-8, 2016 at Biloxi,MS
- Sherman Ivy and Lewis Stafford to travel to quarterly Board Meeting for MS Constable Association in Gulfport, MS, Friday, July 29, 2016
- E911 Dispatchers (4) to travel to Grenada, MS, August 1-2, 2016, Public Safety Academics Class, involving Officer Involved in Shooting and responding to other critical events – Travel is 100% Reimbursed thru Dept of Public Safety
- Beth Lee, E911 Dispatcher to attend training in Philadelphia, MS, August 15-16, 2016 on Crisis and Emergency - 100% Reimbursed by Dept of Public Safety

Motion \_\_\_\_\_

Second \_\_\_\_\_

**ORDER OF BOARD OF SUPERVISORS** Clay COUNTY,  
**SETTING FORTH PROPOSED STATE AID PROJECTS FOR**  
**PERIOD** January, 2016 **THROUGH** December, 2019

Pursuant to the provisions of Senate Bill No. 1 of the Extraordinary Session of 1949 and as subsequently amended herein after referred to as said Act. We the undersigned members of the Board of Supervisors of Clay County hereby order that the proposed project(s) listed herein constitute the State Aid Program for Clay County for the period January, 2016 through December 2019

In support of this order, the Board certifies and agrees that

- 1 The State Aid System in said County has been designated by the Board and approved by the State Aid Engineer, as required by said Act
- 2 The Board has employed a Registered Professional Engineer as County Engineer who will employ such other competent technical assistant(s), as required to properly supervise and inspect the work in compliance with the Rules and Regulations of the State Aid Engineer, all as required in said Act
- 3 This program, which has been prepared by the County Engineer and approved by this Board, is herewith submitted to the State Aid Engineer for approval
- 4 The Board will comply with all applicable Laws, Rules and Regulations in the acquisition of rights-of-way and will maintain the acquired rights-of-way for said project(s) to keep the same free of encroachments such as buildings, fences or any other obstructions. The Board designates \_\_\_\_\_ as its right-of-way acquisition agent for the project(s) herein. The agent's address and phone number is \_\_\_\_\_
- 5 Counties receiving \$500,000 or more in Federal funds from all projects constructed or being constructed in a Federal Fiscal Year (October 1 - September 30) must have a single audit conducted in accordance with OMB circular A-133
- 6 The Board herein affirms its acceptance of the Office of State Aid Road Construction's policy for the accommodation of utilities as stated in S O P No. SA II-2-8 and agrees to coordinate utility facility installation and/or adjustment in a timely manner so as not to impede project development
- 7 The Board will maintain the project(s), after completion, in a regular and satisfactory manner subject to the approval of the State Aid Engineer, all as required in said Act
- 8 The State Aid Engineer is authorized to effect such transfer of funds as are necessary to pay engineering costs on the project(s) as authorized by Mississippi Code 1972, Section 65-9-15 and in accordance with the Rules and Regulations promulgated by the State Aid Engineer dated July 1, 2005
- 9 The State Aid Engineer is authorized to effect such transfer of funds as are necessary to pay testing expenses incurred PRIOR to the award of Contract on any project(s) included in this program. In the event the Board cancels or withdraws any project(s) included in this program, the Board hereby agrees to reimburse its State Aid Fund for testing charges incurred

PROJECT PRIORITY NO

1 Project No SAP 13(8)M  
 2 Name of Road See Attached Sheet  
 3 Design Classification (check one) Rural  Urban  (check one) Collector  Local   
 Federal Route Number \_\_\_\_\_  
 4 Term(s) of Project \_\_\_\_\_

5 Length of Project 5.6 Miles  
 6 Character of Work (Show Alternates if Applicable) Hot Mix Asphalt Overlay Marking Striping and Signing

7 Design Data  
 a. Traffic Count How Determined Variable  
 Current ADT Variable VPD Design Year ADT Variable VPD %Trucks Variable  
 Traffic Count Required Yes  No  (Attach Supplemental Sheet)  
 b. Terrain Level  Rolling  Design Speed 40 MPH  
 c. ROW Existing n/a Ft Proposed n/a Ft  
 d. Proposed Roadway Crown Width \_\_\_\_\_ Ft  
 e. Surface Type & Width Existing See Attached Sheet \_\_\_\_\_ Ft  
 Proposed See Attached Sheet \_\_\_\_\_ Ft

8 Bridges  
 a. Str No \_\_\_\_\_ Suff Rtg \_\_\_\_\_ Capacity \_\_\_\_\_  
 Remain in Place Yes  No  Existing/Proposed Width \_\_\_\_\_ Ft  
 b. Str No \_\_\_\_\_ Suff Rtg \_\_\_\_\_ Capacity \_\_\_\_\_  
 Remain in Place Yes  No  Existing/Proposed Width \_\_\_\_\_ Ft  
 c. Str No \_\_\_\_\_ Suff Rtg \_\_\_\_\_ Capacity \_\_\_\_\_  
 Remain in Place Yes  No  Existing/Proposed Width \_\_\_\_\_ Ft  
 d. Str No \_\_\_\_\_ Suff Rtg \_\_\_\_\_ Capacity \_\_\_\_\_  
 Remain in Place Yes  No  Existing/Proposed Width \_\_\_\_\_ Ft  
 e. Str No \_\_\_\_\_ Suff Rtg \_\_\_\_\_ Capacity \_\_\_\_\_  
 Remain in Place Yes  No  Existing/Proposed Width \_\_\_\_\_ Ft

9 Estimated Construction Cost of Project (Including Contingencies) \$ 1,290,064  
 a. STP Funds Requested ( \_\_\_\_\_ %) \$ \_\_\_\_\_  
 b. BR Funds Requested ( \_\_\_\_\_ %) \$ \_\_\_\_\_  
 c. SA Funds Requested ( 100 %) \$ 1,290,064  
 d. LSBP Funds ( \_\_\_\_\_ %) \$ \_\_\_\_\_  
 e. \_\_\_\_\_ Funds \$ \_\_\_\_\_

Engineering Cost ( 12 %) (Constr Cost Less Contingencies) \$ 147,360  
 a. State Aid Funds Requested \$ \_\_\_\_\_  
 b. County Funds Contributed \$ \_\_\_\_\_  
 c. LSBP Funds Contributed \$ \_\_\_\_\_  
 d. \_\_\_\_\_ Funds Contributed \$ \_\_\_\_\_  
**Total Estimated Cost of Project** \$ 1,437,500

Construction will be by Contract  County Forces \_\_\_\_\_

Use Supplemental Sheet and/or maps if needed to provide complete data

FOR STATE AID USE ONLY

Preliminary Review \_\_\_\_\_ Date  
 Recommend Approval \_\_\_\_\_ Dist Engr \_\_\_\_\_ Date  
 Approved \_\_\_\_\_ State Aid Engr \_\_\_\_\_ Date  
 Letter To Bd \_\_\_\_\_ Dist Engr \_\_\_\_\_ Date  
 Funds Record \_\_\_\_\_ Auditor \_\_\_\_\_ Date  
 Programmed \_\_\_\_\_ Date

BOARD OF SUPERVISORS

Clay County  
[Signature], Supervisor, District I  
[Signature], Supervisor, District II  
[Signature], Supervisor, District III  
[Signature], Supervisor, District IV  
[Signature], Supervisor, District V  
Prepared by Robert I. Calvert, County Engineer

STATE OF MISSISSIPPI  
COUNTY OF Clay

This is to certify that the foregoing is a true and correct copy of an order passed by the Board of Supervisors of Clay County, Mississippi, entered into the minutes of the said Board of Supervisors, Minute Book No 154, Page No 14, same having been adopted at a meeting of said Board of Supervisors on the 28 day of July, 2016

MISSISSIPPI

[Signature]  
Clerk of Board of Supervisors of  
Clay County Mississippi



OFFICE OF STATE AID ROAD CONSTRUCTION  
MISSISSIPPI DEPARTMENT OF TRANSPORTATION  
JACKSON MISSISSIPPI

DATA TO BE SUBMITTED WITH ALL PROJECT PROGRAMS

Project Number SAP 13(8)M County Clay Date \_\_\_\_\_

Road Connections at each End of Project  
See Attached Sheet End Surf Type \_\_\_\_\_ Surf Width \_\_\_\_\_ Rdwy Width \_\_\_\_\_  
 (South or West)  
See Attached Sheet End Surf Type \_\_\_\_\_ Surf Width \_\_\_\_\_ Rdwy Width \_\_\_\_\_  
 (North or East)

Railroad Grade Crossing Data  
 Is there an existing Railroad Grade Crossing? Yes  No \_\_\_\_\_

Name of Railroad Kansas City Southern Railroad

Existing Protection Flashing Signals

Proposed Protection None

Existing and/or Proposed Facilities Effecting Route

SCHOOLS	YES <input checked="" type="checkbox"/>	NO _____	ON ROUTE _____	OFF ROUTE _____
INDUSTRY	YES _____	NO _____	ON ROUTE _____	OFF ROUTE _____

TYPE OF INDUSTRY \_\_\_\_\_

OTHER DESIGN CONSIDERATIONS \_\_\_\_\_  
 \_\_\_\_\_  
 \_\_\_\_\_

UTILITY COMPANIES TO BE AFFECTED BY PROJECT

NAME	STREET OR P.O. BOX ADDRESS	CITY
N/A		

Signed Robert L. Calvert  
 County Engineer

**ATTACHMENT TO ORDER OF  
BOARD OF SUPERVISORS  
CLAY COUNTY, MS  
SAP-13(8)M  
CSE #216016**

Road Designation	Name	Fed Route	Classification	Previous Project	District	Length (Miles)	Existing		Proposed		
							Surface Type	Width	Surface Type	Width	
A	West Point Industrial Road	N/A	Collector	APL-9999(1)B	1	1 5	Hot Mix Asphalt	24	Hot Mix Asphalt	24	
B	Tibbee Road	N/A	Collector	SAP-13(10)	2	1 75	DBST	21	Hot Mix Asphalt	21	
C	Brand Una Road	0744	Collector	APL 0744(4)B	4	1 00	Hot Mix Asphalt	20	Hot Mix Asphalt	20	
D	Pheba South Road	0739	Collector	S 0739-2(1)	5	1 35	Hot Mix Asphalt	20	Hot Mix Asphalt	20	
<b>Total Miles</b>						<b>5 6</b>					

444

405

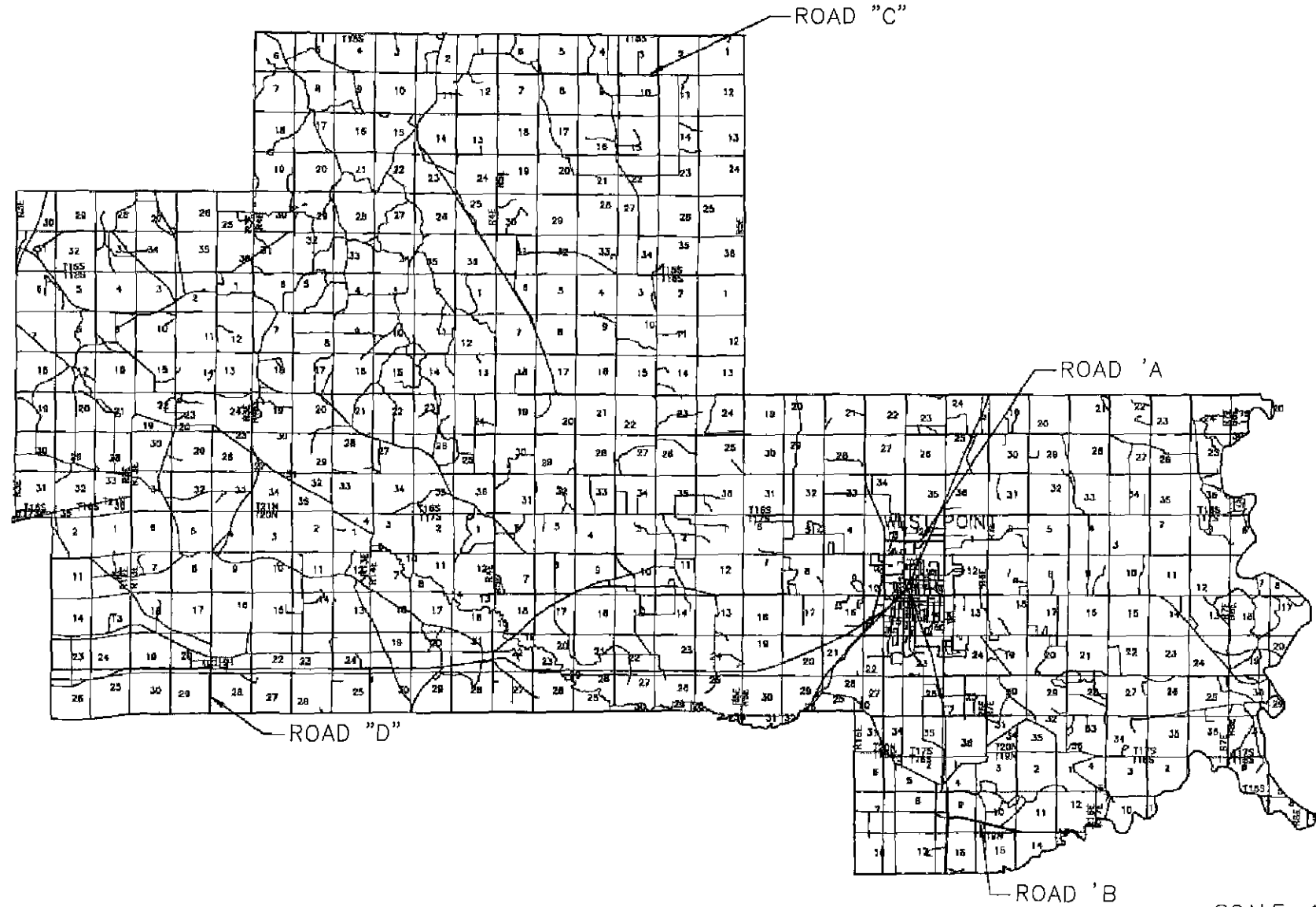

SCALE 1 = 20 000

CALVERT - SPRADLING ENGINEERS INC Consulting Engineers P O Box 1078 • Phone (601) 494-7101 West Point Mississippi 39773	SAP-13(8)M OVERLAY	
	DESIGNED/SURVEYED BY _____ DRAWN BY <u>RLC Jr</u> CHECKED BY <u>RLC</u> DATE <u>7-12-16</u>	SHEET NO <u>1 OF 1</u>
CLAY COUNTY, MISSISSIPPI		

**ORDER OF BOARD OF SUPERVISORS** Clay COUNTY,  
**SETTING FORTH PROPOSED STATE AID PROJECTS FOR**  
**PERIOD** January, 2016 **THROUGH** December, 2019

Pursuant to the provisions of Senate Bill No. 1 of the Extraordinary Session of 1949 and as subsequently amended, herein after referred to as said Act. We, the undersigned members of the Board of Supervisors of Clay County, hereby order that the proposed project(s) listed herein constitute the State Aid Program for Clay County for the period January, 2016 through December, 2019.

In support of this order, the Board certifies and agrees that:

1. The State Aid System in said County has been designated by the Board and approved by the State Aid Engineer as required by said Act.
2. The Board has employed a Registered Professional Engineer as County Engineer who will employ such other competent technical assistant(s) as required, to properly supervise and inspect the work in compliance with the Rules and Regulations of the State Aid Engineer, all as required in said Act.
3. This program, which has been prepared by the County Engineer and approved by this Board, is herewith submitted to the State Aid Engineer for approval.
4. The Board will comply with all applicable Laws, Rules and Regulations in the acquisition of rights-of-way and will maintain the acquired rights-of-way for said project(s) to keep the same free of encroachments such as buildings, fences or any other obstructions. The Board designates \_\_\_\_\_ as its right-of-way acquisition agent for the project(s) herein. The agent's address and phone number is \_\_\_\_\_.
5. Counties receiving \$500,000 or more in Federal funds from all projects constructed or being constructed in a Federal Fiscal Year (October 1 - September 30), must have a single audit conducted in accordance with OMB circular A-133.
6. The Board herein affirms its acceptance of the Office of State Aid Road Construction's policy for the accommodation of utilities as stated in S O P No. SA II-2-8 and agrees to coordinate utility facility installation and/or adjustment in a timely manner so as not to impede project development.
7. The Board will maintain the project(s), after completion, in a regular and satisfactory manner subject to the approval of the State Aid Engineer, all as required in said Act.
8. The State Aid Engineer is authorized to effect such transfer of funds as are necessary to pay engineering costs on the project(s), as authorized by Mississippi Code 1972 Section 65-9-15 and in accordance with the Rules and Regulations promulgated by the State Aid Engineer dated July 1, 2005.
9. The State Aid Engineer is authorized to effect such transfer of funds as are necessary to pay testing expenses incurred PRIOR to the award of Contract on any project(s) included in this program. In the event the Board cancels or withdraws any project(s) included in this program, the Board hereby agrees to reimburse its State Aid Fund for testing charges incurred.

PROJECT PRIORITY NO 2

1 Project No SAP 13(9)M  
 2 Name of Road Siloam Una Road  
 3 Design Classification (check one) Rural  Urban \_\_\_\_\_ (check one) Collector  Local \_\_\_\_\_  
 Federal Route Number 0770  
 4 Termini of Project Begin approximately 2100 feet south of hte NW corner of Sec 11 T16S R52 Clay County and extend north for 2100 feet  
 5 Length of Project 0.4 Miles  
 6 Character of Work (Show Alternates if Applicable) Reconstruction

7 Design Data.  
 a Traffic Count How Determined Estimate  
 Current ADT 230 VPD Design Year ADT 44 VPD %Trucks 10  
 Traffic Count Required. Yes \_\_\_\_\_ No  (Attach Supplemental Sheet)  
 b Terrain Level  Rolling \_\_\_\_\_ Design Speed 40 MPH  
 c ROW Existing 70 Ft Proposed 70 Ft  
 d Proposed Roadway Crown Width 28 Ft  
 e Surface Type & Width Existing Asphlat 20 Ft  
 Proposed Asphalt 20 Ft

8 Bridges  
 a Str No \_\_\_\_\_ Suff Rtg \_\_\_\_\_ Capacity \_\_\_\_\_  
 Remain in Place Yes \_\_\_\_\_ No \_\_\_\_\_ Existing/Proposed Width \_\_\_\_\_ Ft  
 b Str No \_\_\_\_\_ Suff Rtg \_\_\_\_\_ Capacity \_\_\_\_\_  
 Remain in Place Yes \_\_\_\_\_ No \_\_\_\_\_ Existing/Proposed Width \_\_\_\_\_ Ft  
 c Str No \_\_\_\_\_ Suff Rtg \_\_\_\_\_ Capacity \_\_\_\_\_  
 Remain in Place Yes \_\_\_\_\_ No \_\_\_\_\_ Existing/Proposed Width \_\_\_\_\_ Ft  
 d Str No \_\_\_\_\_ Suff Rtg \_\_\_\_\_ Capacity \_\_\_\_\_  
 Remain in Place Yes \_\_\_\_\_ No \_\_\_\_\_ Existing/Proposed Width \_\_\_\_\_ Ft  
 e Str No \_\_\_\_\_ Suff Rtg \_\_\_\_\_ Capacity \_\_\_\_\_  
 Remain in Place Yes \_\_\_\_\_ No \_\_\_\_\_ Existing/Proposed Width \_\_\_\_\_ Ft

9 Estimated Construction Cost of Project (Including Contingencies) \$ 358 974  
 a STP Funds Requested ( \_\_\_\_\_ %) \$ \_\_\_\_\_  
 b BR Funds Requested ( \_\_\_\_\_ %) \$ \_\_\_\_\_  
 c SA Funds Requested ( 100 %) \$ 358 974  
 d LSBP Funds ( \_\_\_\_\_ %) \$ \_\_\_\_\_  
 e \_\_\_\_\_ Funds \$ \_\_\_\_\_

Engineering Cost ( 12 %) (Constr Cost Less Contingencies) \$ 41,026  
 a State Aid Funds Requested \$ \_\_\_\_\_  
 b County Funds Contributed \$ \_\_\_\_\_  
 c LSBP Funds Contributed \$ \_\_\_\_\_  
 d \_\_\_\_\_ Funds Contributed \$ \_\_\_\_\_  
 Total Estimated Cost of Project \$ 400 000

Construction will be by Contract  County Forces \_\_\_\_\_

Use Supplemental Sheet and/or maps if needed to provide complete data

FOR STATE AID USE ONLY Preliminary Review \_\_\_\_\_ Date  
 Recommend Approval \_\_\_\_\_ Dist Engr \_\_\_\_\_ Date  
 Approved \_\_\_\_\_ State Aid Engr \_\_\_\_\_ Date  
 Letter To Bd. \_\_\_\_\_ Dist Engr \_\_\_\_\_ Date  
 Funds Record \_\_\_\_\_ Auditor \_\_\_\_\_ Date  
 Programmed \_\_\_\_\_ Date

BOARD OF SUPERVISORS

[Signature] Clay County  
Supervisor, District I

[Signature] Supervisor, District II

[Signature] Supervisor, District III

[Signature] Supervisor, District IV

[Signature] Supervisor, District V

Prepared by Robert L. Calvert County Engineer

STATE OF MISSISSIPPI  
COUNTY OF Clay

This is to certify that the foregoing is a true and correct copy of an order passed by the Board of Supervisors of Clay County, Mississippi, entered into the minutes of the said Board of Supervisors, Minute Book No 154 Page No       , same having been adopted at a meeting of said Board of Supervisors on the 28th day of July,  
2006

[Signature]  
Clerk of Board of Supervisors of  
Clay County Mississippi

**OFFICE OF STATE AID ROAD CONSTRUCTION  
MISSISSIPPI DEPARTMENT OF TRANSPORTATION  
JACKSON MISSISSIPPI**

DATA TO BE SUBMITTED WITH ALL PROJECT PROGRAMS

Project Number SAP-13(9)M County Clay Date \_\_\_\_\_

Road Connections at each End of Project

<u>South</u>	<u>End</u>	<u>Surf Type</u> <u>Asphalt</u>	<u>Surf Width</u> <u>10</u>	<u>Rdwy Width</u> <u>28</u>
(South or West)				
<u>North</u>	<u>End</u>	<u>Surf Type</u> <u>Asphalt</u>	<u>Surf Width</u> <u>10</u>	<u>Rdwy Width</u> <u>28</u>
(North or East)				

Railroad Grade Crossing Data

Is there an existing Railroad Grade Crossing? Yes \_\_\_\_\_ No

Name of Railroad \_\_\_\_\_

Existing Protection \_\_\_\_\_

Proposed Protection \_\_\_\_\_

Existing and/or Proposed Facilities Effecting Route

SCHOOLS	YES <input checked="" type="checkbox"/>	NO _____	ON ROUTE <input checked="" type="checkbox"/>	OFF ROUTE _____
INDUSTRY	YES _____	NO _____	ON ROUTE _____	OFF ROUTE _____

TYPE OF INDUSTRY \_\_\_\_\_

OTHER DESIGN CONSIDERATIONS \_\_\_\_\_  
 \_\_\_\_\_  
 \_\_\_\_\_

UTILITY COMPANIES TO BE AFFECTED BY PROJECT

NAME	STREET OR P O BOX ADDRESS	CITY
N/A		

Signed Robert L. Calvert  
 County Engineer

500

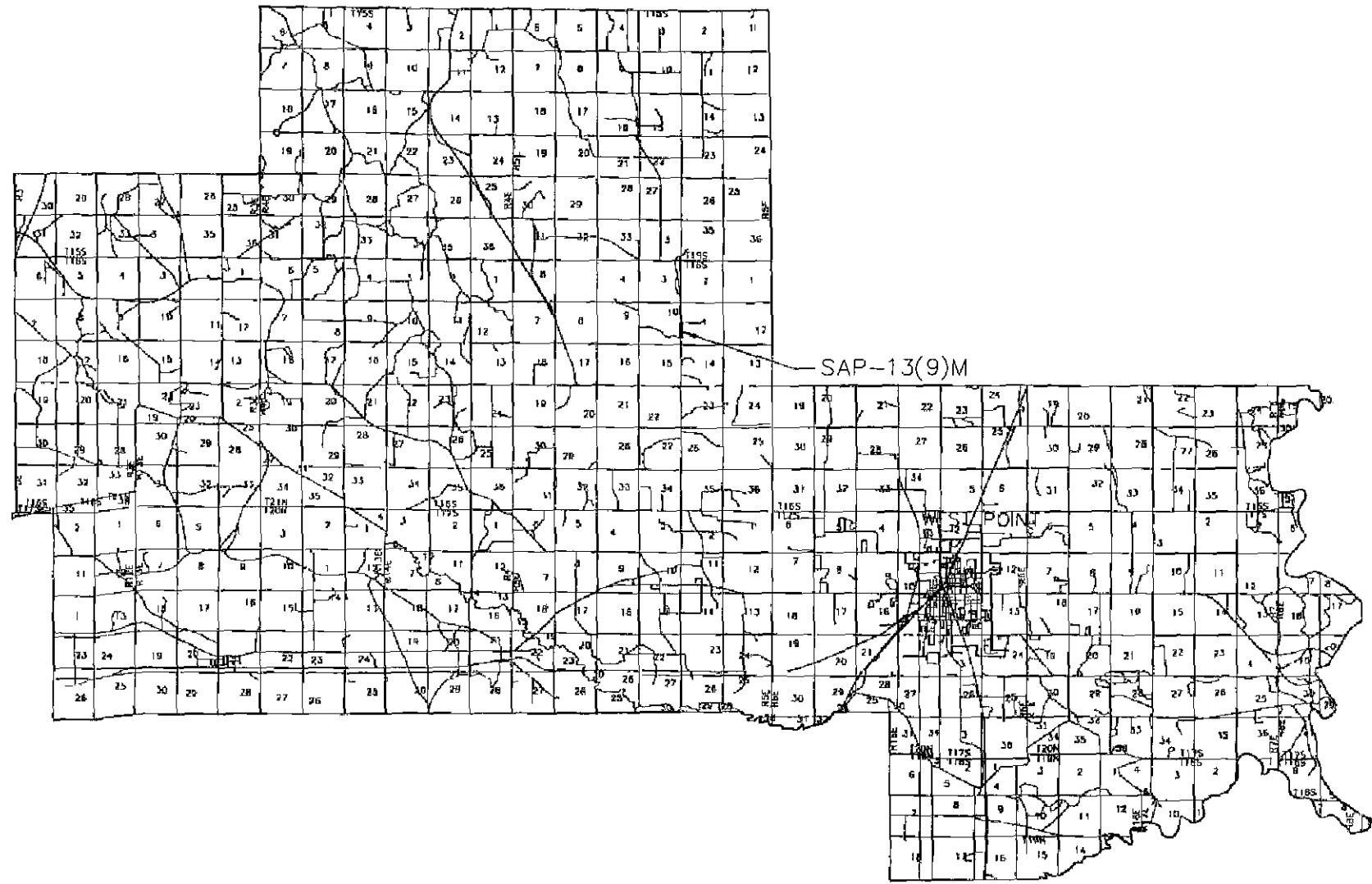

SCALE 1 = 20 000

CALVERT - SPRADLING ENGINEERS INC Consulting Engineers P O Box 1078 * Phone (601) 494-7101 West Point Mississippi 39773	SILOAM-UNA ROAD SAP-13(9)M	
	DESIGNED/SURVEYED BY _____ DRAWN BY <u>RLC Jr.</u> CHECKED BY <u>RLC</u> DATE <u>7-12-16</u>	SHEET NO <u>1</u> OF <u>1</u>

216116 LOCATION DWG



**PROGRAM, AGREEMENT AND PROJECT ORDER FOR INSPECTION OF  
DESIGNATED BRIDGES IN CLAY COUNTY, MISSISSIPPI  
FOR THE STATE FISCAL YEAR OF 2017**

Pursuant to the provisions of governing State and Federal Laws and Regulations, We, the Board of Supervisors of Clay County Mississippi hereinafter referred to as the Board, hereby order that the proposed project listed hereon constitute the Bridge Inspection Program for Clay County, subject to the approval of the State Aid Engineer and Concurrence by the Executive Director of the Mississippi Department of Transportation

In support of this order, the Board certifies and agrees that

- 1 All designated bridges affected by this project are on roads under local jurisdiction (County or City) and are to be inspected, inventoried and evaluated in accordance with the National Bridge Inspection Standards (23 CFR 650 C) hereinafter referred to as the NBIS
- 2 Bridges requiring posting or closure based on this inspection and evaluation will be promptly posted or closed by the County or City (if applicable) in accordance with established standards and procedures
- 3 The Board has employed a Registered Professional Engineer as County Engineer who will provide such other qualified technical personnel to properly supervise and perform the required work in compliance with the rules and regulations of the NBIS and any additional instructions/guidance provided by the State Aid Engineer
- 4 The County Engineer will provide at least one team leader, who meets the minimum qualifications stated in § 650 309 of the NBIS, at the bridge at all times during the inspection as in accordance with required § 650 313 of the NBIS
- 5 The supervision of all phases of the inspection, inventory and evaluation will be the responsibility of the Board, acting through its County Engineer
- 6 A bridge Scour POA (Plan of Action) will be prepared, or revised using the POA developed for scour critical bridges All bridges identified as scour critical will be monitored in accordance with the appropriate POA and regulations set forth in Section 650 313 of the NBIS and the Bridge Inspection Manual prepared by the Office of State Aid Road Construction The Board designates \_\_\_\_\_ as its representative to monitor site conditions in response to an event that requires an inspection as set forth in the Scour POA for each scour critical structure The representative's address and phone number is \_\_\_\_\_

---

If the conditions result in closure of the bridge the representative shall take action to close the bridge in accordance with the bridge Scour POA. If a bridge has been closed or the Board chooses to cause an inspection to be made a certified bridge inspection team will be required to perform the inspection. The representative will contact the County Engineer to request such an inspection. The cost of the inspection of a scour critical bridge following a bridge closure shall be the responsibility of the Board.

- 7 Bridges with Unknown Foundations that have been identified as High or Moderate Risk or those with a Scour rating (Item 113) of three (3) or less, and are not scheduled for this inspection cycle will have a Scour Monitoring Inspection updating the Scour / Waterway Appraisal form and the stream profile in the bridge system. A High Risk Scour POA will be completed for each bridge identified as high risk. A High Risk bridge will be monitored as a Scour Critical bridge following the guidelines in (6) above.
- 8 The County Engineer will maintain a bridge file on behalf of the County for each bridge in accordance with the regulations set forth in § 650 313 (d) of the NBIS. Bridge files shall remain the property of the Board.
- 9 The County Engineer will provide a Quality Control Manager (QC Manager) as set forth in the National Bridge Inspection Local System Manual, Section 16 Quality Control Program. The QC Manager shall meet or exceed the requirements of subsection 4.4 of the National Bridge Inspection Local System Manual.
- 10 The number of bridges selected for evaluation and a follow-up on-site inspection by the QC manager will be 5% of the county inventory or a minimum of 5 bridges.
- 11 All required data shall be entered into the State Aid/ InspectTech web-based Bridge Inspection System and approved by the County Engineer in a timely manner. Bridge data should be input as soon as possible following the inspection.
- 12 All components of the bridge file will be made available to authorized representatives of State Aid and/or FHWA for inspection and review at all reasonable times in the General Offices of the County Engineer.
- 13 After final completion of the work and acceptance by the State Aid Engineer, the Board will be paid on the basis of the final quantities at the agreed unit prices specified below.

14 The inspection shall be completed on or before February 15, 2017

Project Number BR-NBIS(087)B, BRIS-13(87)

Road Designation All Locally - Maintained Roads "ON" and "OFF" Federal-Aid Highways

Character of Work Inspection, Inventory, and Evaluation of Designated Bridges

**Estimated Project Cost**

<b>Bridge Inspections</b>				
A	<u>42</u>	Bridges	@ \$350 00 per bridge	\$ <u>14,700 00</u>
<b>QC Inspections</b>				
B	<u>5</u>	Bridges	@ \$350 00 per bridge	\$ <u>1 750 00</u>
<b>Scour Monitoring Inspections</b>				
C	<u>11</u>	Bridges	@ \$120 00 per bridge	\$ <u>1320 00</u>
D	Subtotal all Inspections			\$ <u>17,770 00</u>
E	Contingencies @ Approximately (4%)			\$ <u>710 00</u>
F	Total Estimated Cost			\$ <u>18,480 00</u>
G	Federal Bridge Replacement Funds Requested			\$ <u>14,784 00</u>
H	Federal Off-System Bridge Credit Requested			\$ <u>3,696 00</u>

;







15 Based upon the estimated quantities of work and agreed unit cost and in support of the herein listed program, we, the Board for Clay County desire to, and hereby adopt the following Order for Project Funds for Clay County Project Number BRIS-13(87)

IT IS THEREFORE, NOW ORDERED by this Board that the total Project Fund for BRIS-13(87) in the amount of \$ 18,480.00, be established by transferring \$ 3,696.00 from Clay County's Federal Off System Bridge Program Credit Fund to the Project Fund, to match \$ 14,784.00 of Bridge Replacement Funds now available for this project

IN WITNESS WHEREFORE, The parties have hereunto affixed their signatures, the Board on the 28<sup>th</sup> day of July, 2016 and the State Aid Engineer on the \_\_\_\_\_ day of \_\_\_\_\_,

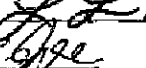
BOARD OF SUPERVISORS

CLAY COUNTY

	_____	President
	_____	Member
	_____	Member
	_____	Member
	_____	Member
	_____	County Engineer

\_\_\_\_\_  
State Aid Engineer

\_\_\_\_\_  
Executive Director, MDOT

STATE OF MISSISSIPPI  
COUNTY OF CLAY

This is to certify that the foregoing is a true and correct copy of an order passed by the Board of Supervisors of Clay County, Mississippi, entered into the minutes of the said Board of Supervisors', Minute Book No 154, Page No \_\_\_\_\_, same having been adopted at a meeting of said Board of Supervisors on the 28<sup>th</sup> day of July, 2016

(SEAL)

  
Chancery Clerk  
Clay County, Mississippi

505

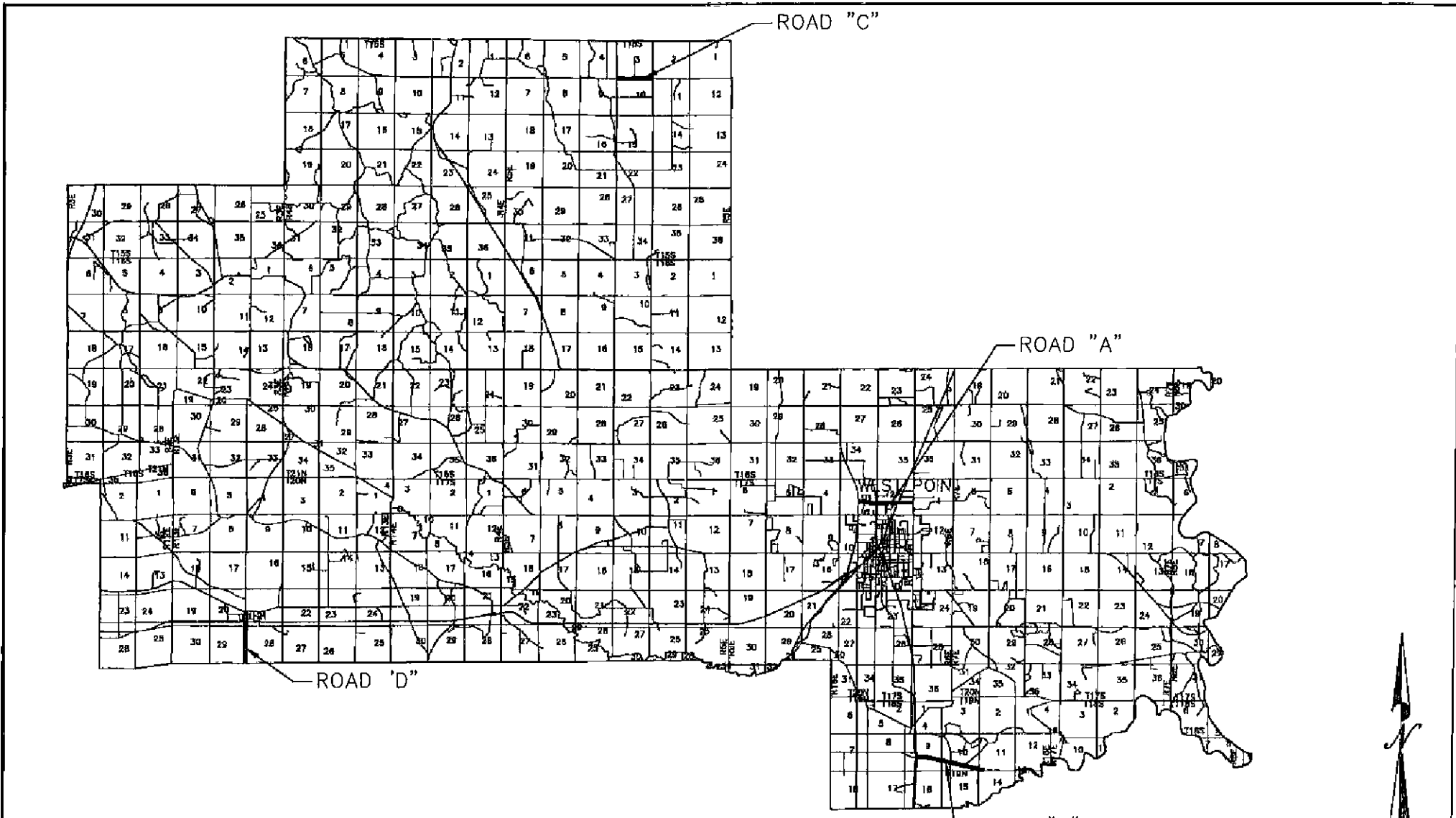

SCALE 1"=20 000

CALVERT - SPRADLING ENGINEERS INC Consulting Engineers P O Box 1078 • Phone (601) 494-7101 West Point Mississippi 39773	SAP-13(8)M OVERLAY	
	DESIGNED/SURVEYED BY _____ DRAWN BY <u>RLC Jr.</u> CHECKED BY <u>RLC</u> DATE <u>7-12-16</u>	SHEET NO <u>1</u> OF <u>1</u>

506

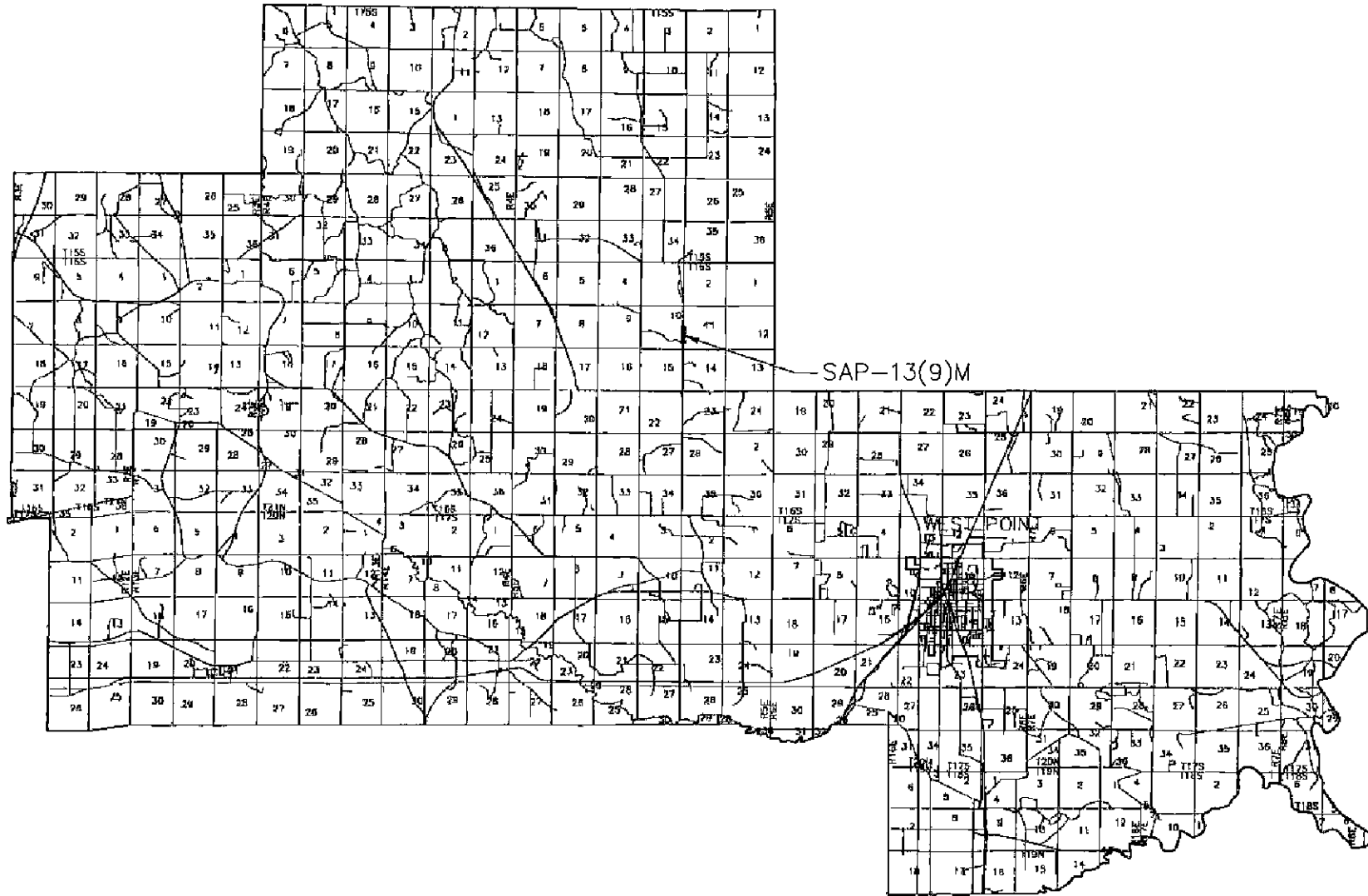

SAP-13(9)M

SCALE 1 = 20 000

CALVERT - SPRADLING ENGINEERS INC Consulting Engineers P O Box 1078 * Phone (601) 494-7101 West Point Mississippi 39773	SILOAM-UNA ROAD SAP-13(9)M	
	CLAY COUNTY, MISSISSIPPI	DESIGNED/SURVEYED BY _____ DRAWN BY <u>RLC Jr.</u> CHECKED BY <u>RLC</u> DATE <u>7-12-16</u>

216116 LOCATION DWG

NO \_\_\_\_\_

**IN THE MATTER OF APPROVING UTILITY PERMITS**

---

There came on this day for consideration the matter of approving utility permits

It appears to this board three (3) utility permits have been received for this Board's approval as attached hereto as Exhibit A and are being recommended by the County Engineer, Robert Calvert

After motion by Luke Lummus and second by Shelton Deanes this Board doth vote unanimously to authorize and approve the said utility permits as attached hereto as Exhibit A

SO ORDERED this the 28<sup>th</sup> day of July, 2016

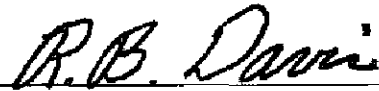

\_\_\_\_\_  
President

PERMIT APPLICATION FOR USE AND OCCUPANCY AGREEMENT  
FOR THE CONSTRUCTION OR ADJUSTMENT OF A UTILITY  
WITHIN COUNTY ROAD RIGHT-OF-WAY

PROJECT NO \_\_\_\_\_ COUNTY Clay

UTILITY NAME Old Waverly Golf Club

BY George Bryan  
(Name & Company Title)

ADDRESS One Magnolia Drive, West Point, MS 39773, herein called APPLICANT,

proposes to construct water  
(Type of Facility)

along or across Old Waverly Road, said facility to be  
(Name of Road)

installed between Station No \_\_\_\_\_ and Station No \_\_\_\_\_ and within the road

right-of-way, and hereby makes application to the County for the construction permit Attached hereto are drawings or plans for the construction, which will not be changed or altered without approval of the Board of Supervisors, or its authorized representative

WHEREAS, the Legislature of Mississippi has heretofore granted to the Applicant the right to locate its facilities upon, across, under, over and along public roads and streets within the State of Mississippi, Applicant agrees to comply with applicable provisions of S O P No SA II-2-8, Policy for the Accommodation of Utility Facilities within the Rights-of-Way of County Federal Aid and State Aid Roads (hereinafter referred to as the 'Policy'), promulgated by the State Aid Engineer and dated July 1, 2005, and which is hereby made a part of this Application Agreement, and agrees to perform the construction according to the applicable industry code and according to the plans and specifications for the project

The Applicant shall be responsible for future maintenance and repair of the facilities The Applicant shall make future adjustments in, or relocate, the facilities located within the road right of-way when required for road widening, construction or maintenance, and its right to reimbursement of its costs shall be in accordance with State Laws affecting County roads in effect at the time such adjustment or relocation is made Further, any maintenance, repair, or construction shall be done in such a manner as to occasion no unreasonable interference with the normal flow and safety of traffic



A general description of the size, type, nature, and extent of the Utility work to be done is as follows

**8" PVC water main through 60'-16" Steel Casing (B&J) across right-of-way of Old Waverly Road**

The Applicant understands and agrees that, except as herein granted no right, title, claim, or easement to said road right-of-way is granted by the issuance of this permit and that if this Utility Facility is not placed within the allowable horizontal and vertical limits as listed in the general provisions of the Policy, it will be adjusted to comply with same without cost to the County, unless the variance from the Policy has been approved by the granting of the Permit pursuant to this Application

\_\_\_\_\_ Clay \_\_\_\_\_ County agrees to the following stipulations

- (1) To cooperate with the Utility Company in every way to avoid conflicts in the location, construction, and maintenance of the County road and Utility Facility
- (2) To pursue any and all legal means to see that Policy Standards, except to the extent of any variance shown on the plans filed herewith and approved, are complied with in the facility installation
- (3) If the County/LSBP Engineer or other authorized representative of the Board of Supervisors approved the drawings, sketches, and plans submitted by the Applicant he shall so indicate by signing and dating the Permit Approval at the end of this Application and the Applicant may proceed with the installation, if the drawings, sketches and plans are not approved he shall promptly notify the Applicant, and advise him of the reason or reasons He will also act as the duly appointed representative of the Board of Supervisors and will give his approval to the completed work as being in compliance with the location and standards shown in the Policy and in this Agreement for the installation
- (4) That all joint road construction and utility adjustment or relocation operations will comply with the requirements of Section S-105 06 and Section S-107 18 Mississippi Standard Specifications for State Aid Road and Bridge Construction 2004 edition (or current edition)
- (5) Should any terms or provision of this Agreement conflict with the Laws of the State of Mississippi, or the United States, or impair or deny to the Applicant or the County any right protected thereby, it shall be deemed amended to conform to said Laws

WITNESS THE SIGNATURE OF THE APPLICANT this the 20<sup>th</sup> day of

July, 2016

By

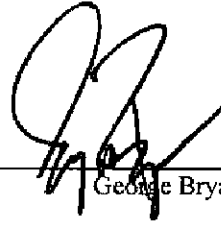

George Bryan

Title

Manager

AGREED TO AND APPROVED BY ORDER OF THE

Clay

COUNTY BOARD OF SUPERVISORS this the 28 day of

July

2016

By

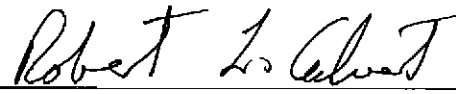

County/LSBP Engineer

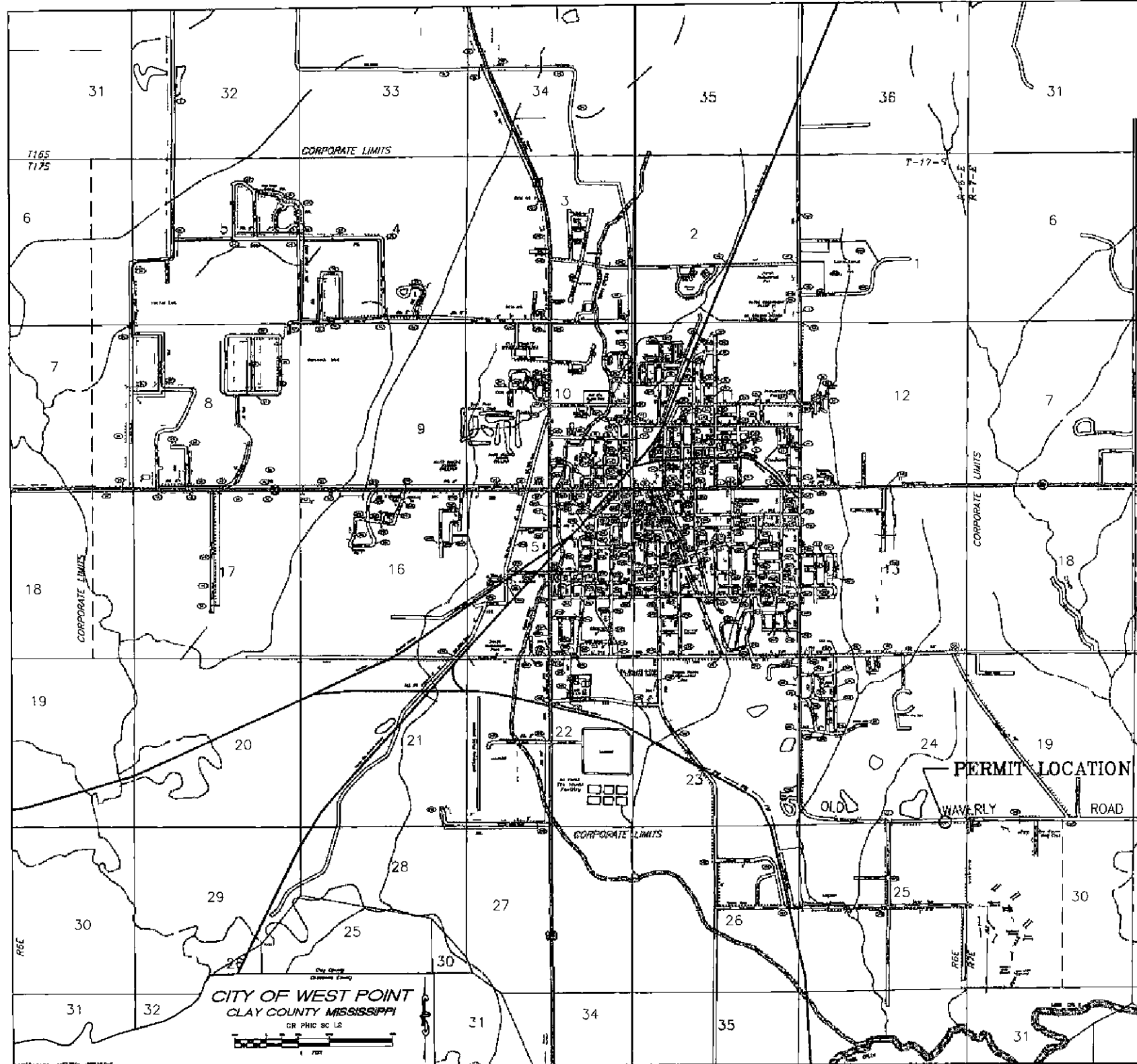

512

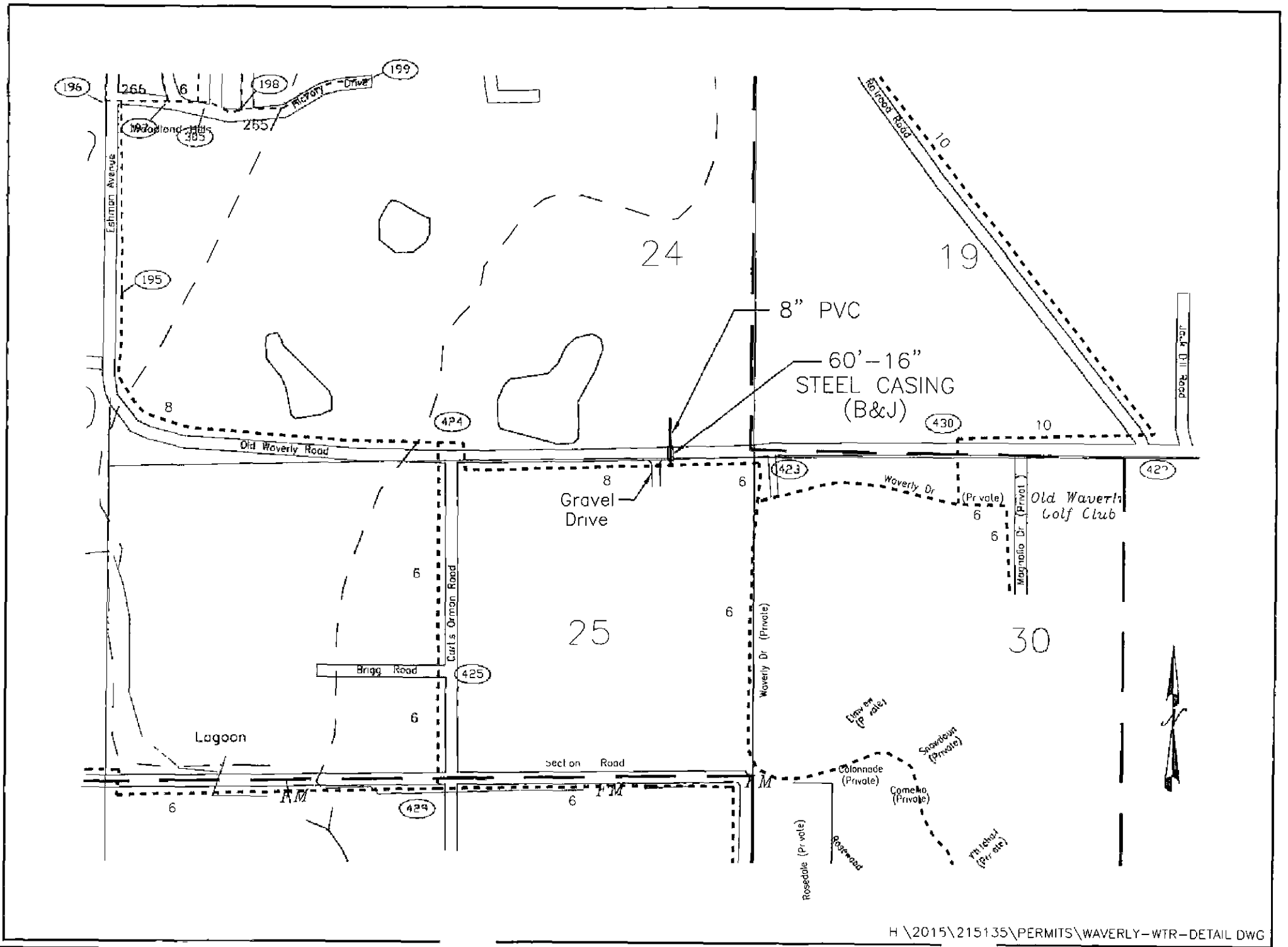

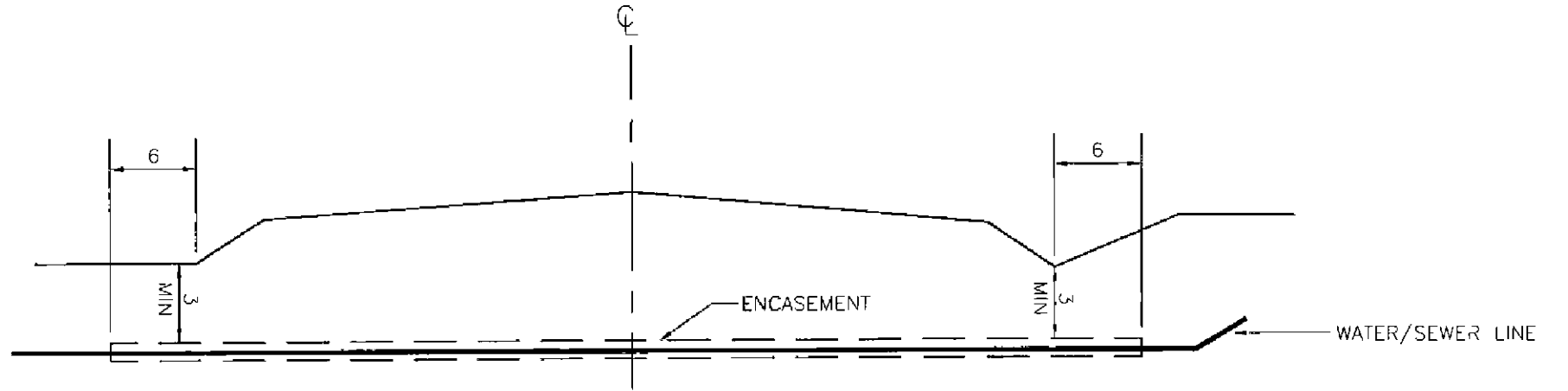

NOTE  
CASING LENGTHS SHOWN  
ON PLAN SHEETS

TYPICAL SECTION - COUNTY ROADS  
BORE DETAIL

NO SCALE

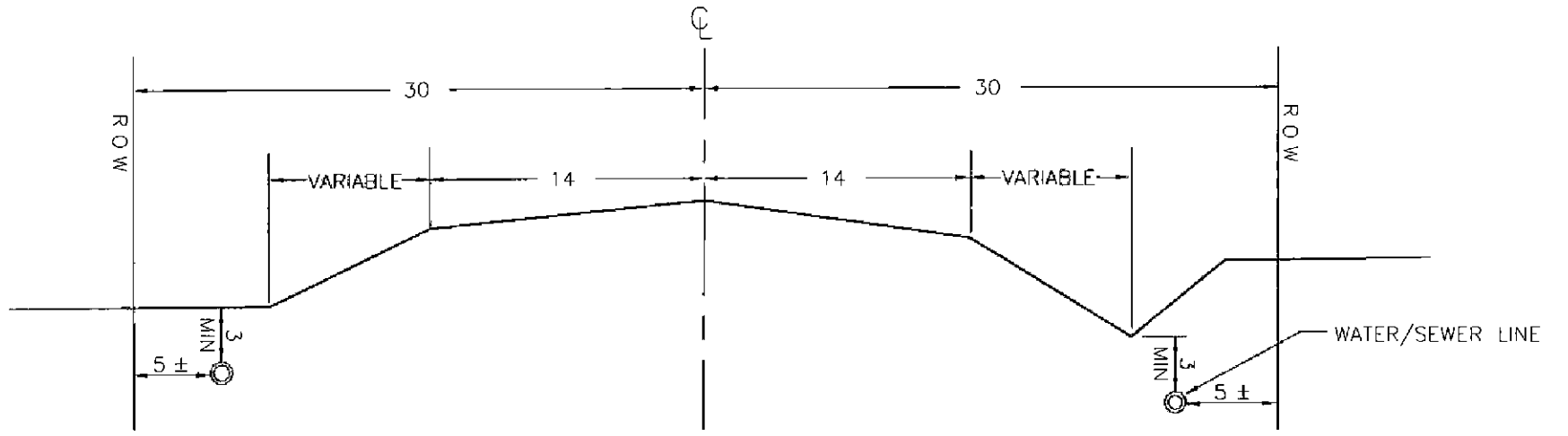

PARALLEL LOCATION - COUNTY ROADS  
WATER/SEWER LINES

NO SCALE

H \ DETAIL \ STADTYP - COUNTY DWG

PERMIT APPLICATION FOR USE AND OCCUPANCY AGREEMENT  
FOR THE CONSTRUCTION OR ADJUSTMENT OF A UTILITY  
WITHIN COUNTY ROAD RIGHT-OF-WAY

PROJECT NO \_\_\_\_\_ COUNTY Clay

UTILITY NAME Old Waverly Golf Club

BY George Bryan  
(Name & Company Title)

ADDRESS One Magnolia Drive, West Point, MS 39773, herein called APPLICANT,

proposes to construct sewer  
(Type of Facility)

along or across Old Waverly Road, said facility to be  
(Name of Road)

installed between Station No \_\_\_\_\_ and Station No \_\_\_\_\_ and within the road  
right-of-way, and hereby makes application to the County for the construction permit Attached hereto are  
drawings or plans for the construction which will not be changed or altered without approval of the Board of  
Supervisors, or its authorized representative

WHEREAS, the Legislature of Mississippi has heretofore granted to the Applicant the right to locate its  
facilities upon, across, under, over and along public roads and streets within the State of Mississippi, Applicant  
agrees to comply with applicable provisions of S O P No SA II-2-8, Policy for the Accommodation of Utility  
Facilities within the Rights-of-Way of County Federal Aid and State Aid Roads (hereinafter referred to as the  
"Policy ), promulgated by the State Aid Engineer and dated July 1, 2005, and which is hereby made a part of this  
Application Agreement, and agrees to perform the construction according to the applicable industry code and  
according to the plans and specifications for the project

The Applicant shall be responsible for future maintenance and repair of the facilities The Applicant shall  
make future adjustments in, or relocate, the facilities located within the road right-of-way when required for road  
widening, construction or maintenance, and its right to reimbursement of its costs shall be in accordance with State  
Laws affecting County roads in effect at the time such adjustment or relocation is made Further, any  
maintenance, repair, or construction shall be done in such a manner as to occasion no unreasonable interference  
with the normal flow and safety of traffic

A general description of the size, type, nature, and extent of the Utility work to be done is as follows

**8" PVC Sewer Main through 70'-16" Steel Casing (B&J) across right-of-way of Old Waverly Rd**

The Applicant understands and agrees that except as herein granted no right title, claim or easement to said road right-of-way is granted by the issuance of this permit and that if this Utility Facility is not placed within the allowable horizontal and vertical limits as listed in the general provisions of the Policy, it will be adjusted to comply with same without cost to the County, unless the variance from the Policy has been approved by the granting of the Permit pursuant to this Application

Clay County agrees to the following stipulations

- (1) To cooperate with the Utility Company in every way to avoid conflicts in the location, construction, and maintenance of the County road and Utility Facility
- (2) To pursue any and all legal means to see that Policy Standards, except to the extent of any variance shown on the plans filed herewith and approved, are complied with in the facility installation
- (3) If the County/LSBP Engineer or other authorized representative of the Board of Supervisors approved the drawings, sketches, and plans submitted by the Applicant, he shall so indicate by signing and dating the Permit Approval at the end of this Application and the Applicant may proceed with the installation, if the drawings, sketches, and plans are not approved he shall promptly notify the Applicant, and advise him of the reason or reasons He will also act as the duly appointed representative of the Board of Supervisors and will give his approval to the completed work as being in compliance with the location and standards shown in the Policy and in this Agreement for the installation
- (4) That all joint road construction and utility adjustment or relocation operations will comply with the requirements of Section S-105 06 and Section S-107 18, Mississippi Standard Specifications for State Aid Road and Bridge Construction 2004 edition (or current edition)
- (5) Should any terms or provision of this Agreement conflict with the Laws of the State of Mississippi, or the United States or impair or deny to the Applicant or the County any right protected thereby, it shall be deemed amended to conform to said Laws

WITNESS THE SIGNATURE OF THE APPLICANT this the 20<sup>th</sup> day of

July, 2016

By \_\_\_\_\_

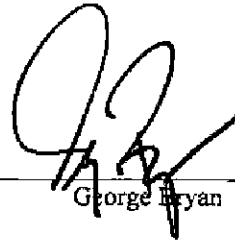

George Bryan

Title Manager

AGREED TO AND APPROVED BY ORDER OF THE Clay

COUNTY BOARD OF SUPERVISORS this the 28<sup>th</sup> day of July

2016

By \_\_\_\_\_

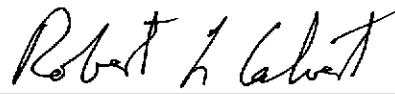

County/LSBP Engineer



517

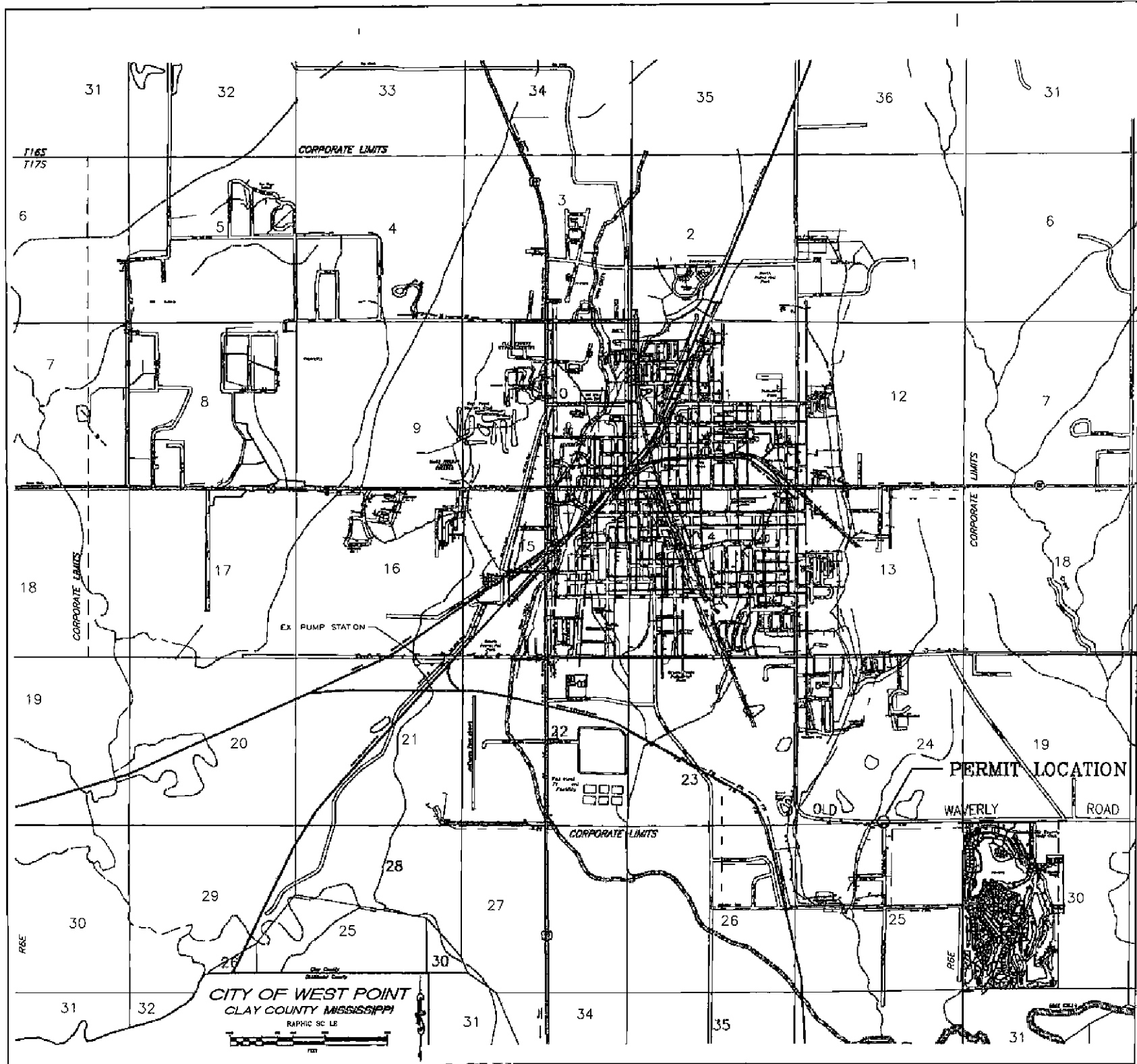

518

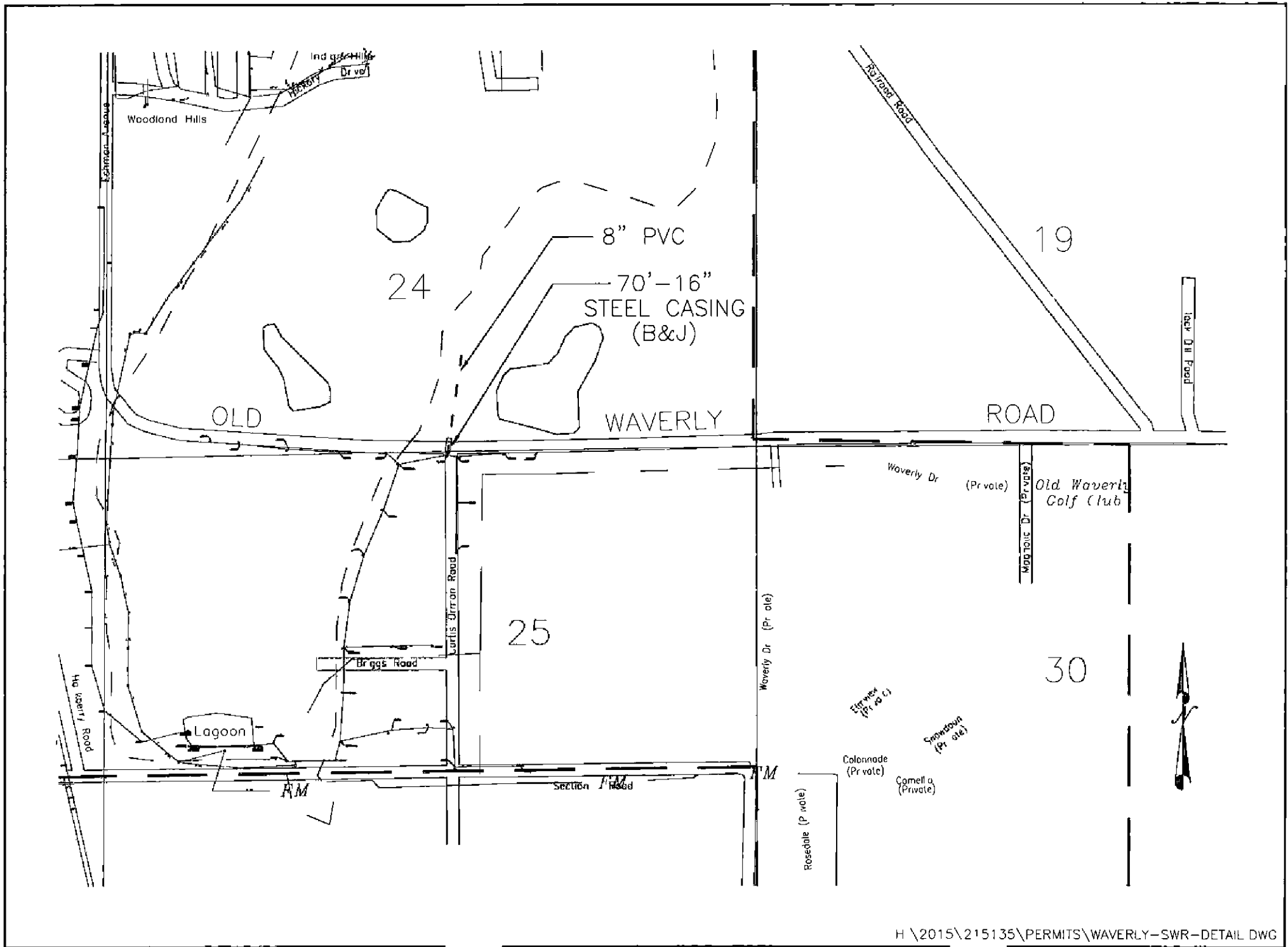

519

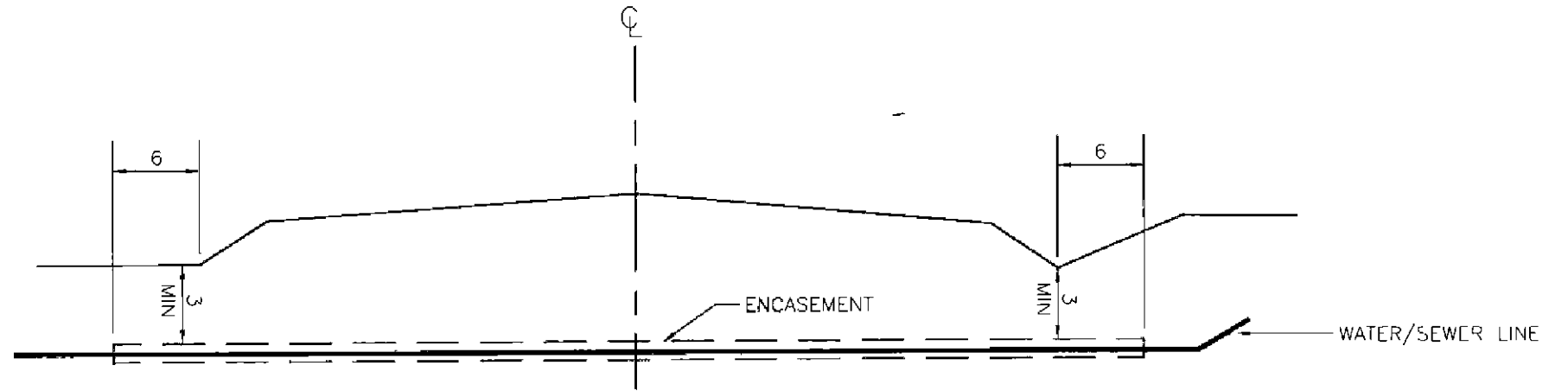

NOTE  
CASING LENGTHS SHOWN  
ON PLAN SHEETS

TYPICAL SECTION - COUNTY ROADS  
BORE DETAIL

NO SCALE

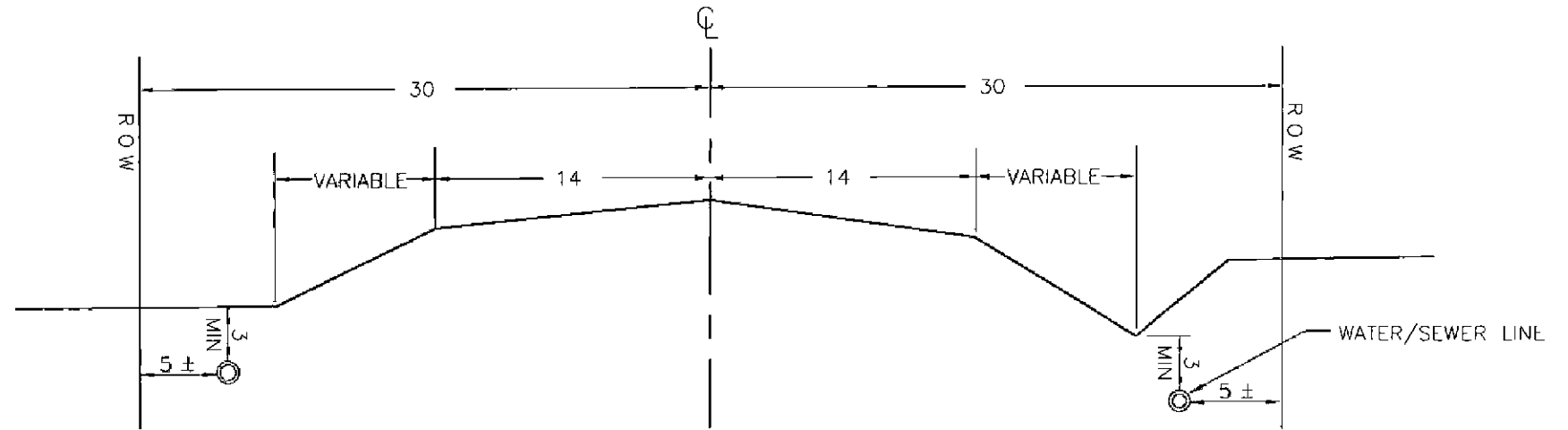

PARALLEL LOCATION - COUNTY ROADS  
WATER/SEWER LINES

NO SCALE

PERMIT APPLICATION FOR USE AND OCCUPANCY AGREEMENT FOR

THE CONSTRUCTION OR ADJUSTMENT OF A UTILITY

WITHIN ROAD OR HIGHWAY RIGHT-OF-WAY

FACILITY ALONG OR ACROSS Yokohama Blvd COUNTY ROAD

PROJECT NO \_\_\_\_\_ COUNTY OF Clay

UTILITY NAME Litwiler Farms BY MARSHALL Litwiler  
(Company Title)

Landowner 707 E. HAZELWOOD RD }  
operator 6210 Hwy #45 N } WEST POINT  
ADDRESS \_\_\_\_\_ HEREIN CALLED APPLICANT,

proposes to construct 10m fore under Yokohama Blvd Utility Facility

along or across \_\_\_\_\_, said facility to be  
(Name of Road)

installed between Sta 67+00 and Sta 68+00

of Project No \_\_\_\_\_ and within road or highway right-of-way, and hereby makes application to the County for the construction permit Attached hereto are drawings or plans for the construction, which will not be changed or altered without approval of the Board of Supervisors, or its authorized representative

WHEREAS, the Legislature of Mississippi has heretofore granted to the Applicant the right to locate its facilities upon, across, under, over and along public highways and streets within the State of Mississippi, Applicant agrees to comply with applicable provisions of S O P No SAD II-2-8, Policy for the Accommodation of Utility Facilities within the Rights-of-Way of County Federal Aid and State Aid Highways (hereinafter referred to as the 'Policy'), promulgated by the State Aid Engineer and dated January 1, 1983, and which is hereby made a part of this Application Agreement, and agrees to perform the construction according to the applicable industry code and according to the plans and specifications for the Project

The Applicant shall be responsible for future maintenance and repair of the facilities The Applicant shall make future adjustments in, or relocate the facilities located within road or highway right-of-way when required for highway widening or other highway construction, and its right to reimbursement of its costs, if any, shall be in accordance with State law in effect at the time such adjustment or relocation is made Further, any maintenance, repair, or construction shall be done in such a manner as to occasion no unreasonable interference with the normal flow and safety of traffic

- 1 -  
(Rev 6-14-90)

FORM-SAD ROW-U2

A general description of the size, type nature, and extent of the Utility work to be done is as follows

*see attached paper*

The Applicant understands and agrees that, except as herein granted, no right, title, claim, or easement to said road right-of-way is granted by the issuance of this permit and that if this Utility Facility is not placed within the allowable horizontal and vertical limits as listed in the general provisions of the Policy, it will be adjusted to comply with same without cost to the County, unless the variance from the Policy has been approved by the granting of the Permit pursuant to this Application

The Applicant further understands that the Utility's engineering, plant, or other personnel will be responsible for the staking and construction supervision of the work set out above and as shown on the attached plans

\_\_\_\_\_ County agrees to the following stipulations

- (1) To cooperate with the Utility Company in every way to avoid conflicts in the location, construction, and maintenance of the County Highway and Utility Facility
- (2) To pursue any and all legal means to see that Policy Standards, except to the extent of any variance shown on the plans filed herewith and approved, are complied with in the facility installation
- (3) If the County Engineer or other authorized representative of the Board of Supervisors approved the drawings, sketches, and plans submitted by the Applicant, he shall so indicate by signing and dating the Permit Approval at the end of this Application, and the Applicant may proceed with the installation, if the drawings, sketches, and plans are not approved, he shall promptly notify the Applicant, and advise it of the reason or reasons He will also act as the duly appointed representative of the Board of Supervisors and will give his approval to the completed work as being in compliance with the location and standards shown in the Policy and in this Agreement for the installation
- (4) That all joint highway construction and utility adjustment or relocation operations will comply with the requirements of Section S-105 06 and Section S-107 18, Mississippi Standard Specifications for State Aid Road and Bridge Construction, 1989 edition (or current edition)
- (5) Should any term or provision of this Applicant Agreement conflict with the law of the State of Mississippi, the Mississippi Constitution, or the United States Constitution, or impair or deny to the Applicant or the County any right protected thereby, it shall be deemed to conform to said law or Constitution

- 2 -

(Rev 6-14-90)

FORM-SAD ROW-U2

Macintosh HD Users ingabass Documents Microsoft User Data Saved Attachments Utility Permit Form doc

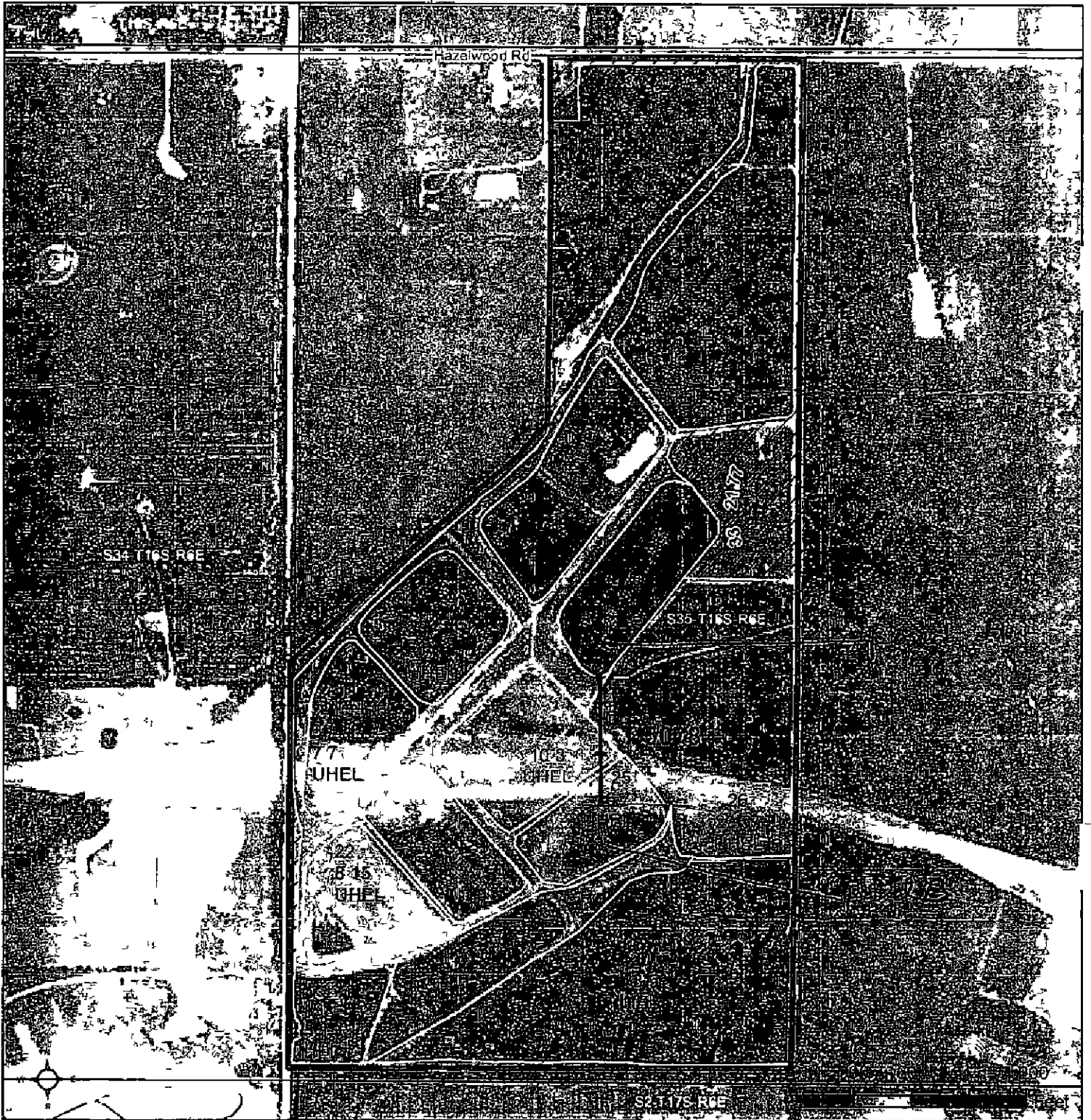

**Common Land Unit** / Non Cropland  
 clu\_classification\_code [Symbol] Tract Boundary  
 Cropland

2015 Program Year  
 Map Created March 09 2015

**Wetland Determination Identifiers**  
 ● Restricted Use  
 ▽ Limited Restrictions  
 ■ Exempt from Conservation  
 ■ Compliance Provisions

Tract Cropland Total 217 80 acres

Farm 2318  
 Tract 5078

United States Department of Agriculture (USDA) Farm Service Agency (FSA) maps are for FSA Program administration only. This map does not represent a legal survey or reflect actual ownership, rather it depicts the information provided directly from the producer and/or National Agricultural Imagery Program (NAIP) imagery. The producer accepts the data as is and assumes all risks associated with its use. USDA-FSA assumes no responsibility for actual or consequential damage incurred as a result of any user's reliance on this data outside FSA Programs. Wetland identifiers do not represent the size, shape, or specific determination of the area. Refer to your original determination (CPA-026 and attached maps) for exact boundaries and determinations or contact USDA Natural Resources Conservation Service (NRCS).

WITNESS the signature of the Applicant this the 17 day of March 2016

By Wayne Situmler

Title landowner

farm operator \_\_\_\_\_

AGREED TO AND APPROVED BY

Clay COUNTY

BOARD OF SUPERVISORS

By Robert L. Calvert  
County Engineer

July 28 2016  
(Month) (Day) (Year)

BY ORDER OF THE BOARD OF SUPERVISORS, Dated the 28<sup>th</sup> Day of July

2016 of Clay County Mississippi The permit for the installation or adjustment of the utility applied for above is granted

ATTACHMENT ' A '

- 1 The utility company agrees to notify the County Road Foreman 24 hours in advance of the commencement of any work on the county Highways
- 2 All facilities will be located no closer to the roadway than the bottom of the ditch or toe of fill unless on site approval is given by the County Road Foreman for each requested road variance
- 3 Upon completion of the work and prior to final acceptance the utility company or its representative agrees to hold a final inspection with the County Road Foreman

- 4 -  
(Rev 6-14-90)

FORM-SAD ROW-U2

Macintosh HD Users \ngabass Documents Microsoft User Data Saved Attachments Utility Permit Form.doc



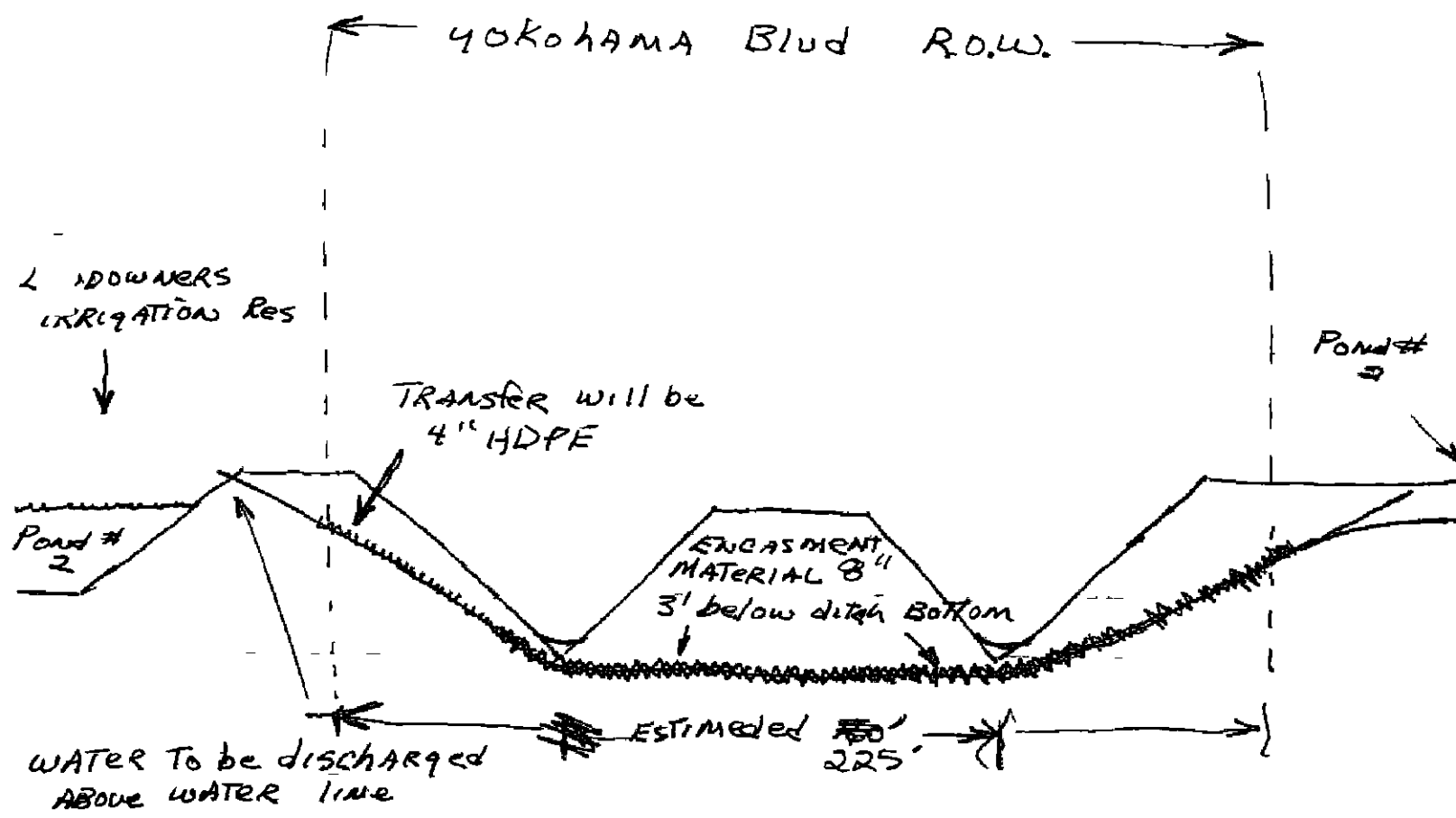

Length of Encasement to be determined by  
 CALVERT-SPREADING ENGINEER, West Point  
 Row - Row



# CERTIFICATE OF LIABILITY INSURANCE

DATE (MM/DD/YYYY)  
7/21/2016

THIS CERTIFICATE IS ISSUED AS A MATTER OF INFORMATION ONLY AND CONFERS NO RIGHTS UPON THE CERTIFICATE HOLDER THIS CERTIFICATE DOES NOT AFFIRMATIVELY OR NEGATIVELY AMEND EXTEND OR ALTER THE COVERAGE AFFORDED BY THE POLICIES BELOW THIS CERTIFICATE OF INSURANCE DOES NOT CONSTITUTE A CONTRACT BETWEEN THE ISSUING INSURER(S) AUTHORIZED REPRESENTATIVE OR PRODUCER AND THE CERTIFICATE HOLDER

**IMPORTANT** If the certificate holder is an ADDITIONAL INSURED the policy(res) must be endorsed If SUBROGATION IS WAIVED subject to the terms and conditions of the policy certain policies may require an endorsement. A statement on this certificate does not confer rights to the certificate holder in lieu of such endorsement(s)

<b>PRODUCER</b> Fisher Brown Bottrell Insurance Inc P O Box 1490 Jackson MS 39215	<b>CONTACT NAME</b> PHONE (A/C, No, Ext) (601) 960 8200      FAX (A/C, No) (601) 208 7484 E-MAIL ADDRESS	
	<b>INSURER(S) AFFORDING COVERAGE</b>	
<b>INSURED</b>  Delta Boring Service LLC 510 Pine Grove Road Magee MS 39111	<b>INSURER A</b> Brierfield Insurance Company      NAIC # 10993	
	<b>INSURER B</b> Berkley Insurance Company      32603	
	<b>INSURER C</b>	
	<b>INSURER D</b>	
	<b>INSURER E</b>	
	<b>INSURER F</b>	

## COVERAGES      CERTIFICATE NUMBER      REVISION NUMBER

THIS IS TO CERTIFY THAT THE POLICIES OF INSURANCE LISTED BELOW HAVE BEEN ISSUED TO THE INSURED NAMED ABOVE FOR THE POLICY PERIOD INDICATED NOTWITHSTANDING ANY REQUIREMENT TERM OR CONDITION OF ANY CONTRACT OR OTHER DOCUMENT WITH RESPECT TO WHICH THIS CERTIFICATE MAY BE ISSUED OR MAY PERTAIN THE INSURANCE AFFORDED BY THE POLICIES DESCRIBED HEREIN IS SUBJECT TO ALL THE TERMS EXCLUSIONS AND CONDITIONS OF SUCH POLICIES LIMITS SHOWN MAY HAVE BEEN REDUCED BY PAID CLAIMS

INSR LTR	TYPE OF INSURANCE	ADDL INSD	SUBR WVO	POLICY NUMBER	POLICY EFF (MM/DD/YYYY)	POLICY EXP (MM/DD/YYYY)	LIMITS
A	<input checked="" type="checkbox"/> COMMERCIAL GENERAL LIABILITY <input type="checkbox"/> CLAIMS MADE <input checked="" type="checkbox"/> OCCUR  GEN L AGGREGATE LIMIT APPLIES PER <input type="checkbox"/> POLICY <input checked="" type="checkbox"/> PROJECT <input type="checkbox"/> LOC <input type="checkbox"/> OTHER			GL0017809	04/17/2016	04/17/2017	EACH OCCURRENCE \$ 1 000 000 DAMAGE TO RENTED PREMISES (Ea occurrence) \$ 100 000 MED EXP (Any one person) \$ 5 000 PERSONAL & ADV INJURY \$ 1 000 000 GENERAL AGGREGATE \$ 2 000 000 PRODUCTS COMP/OP AGG \$ 2,000 000 \$
	<b>AUTOMOBILE LIABILITY</b> <input type="checkbox"/> ANY AUTO <input type="checkbox"/> ALL OWNED AUTOS <input type="checkbox"/> SCHEDULED AUTOS <input type="checkbox"/> HIRED AUTOS <input type="checkbox"/> NON-OWNED AUTOS						COMBINED SINGLE LIMIT (Ea accident) \$ BODILY INJURY (Per person) \$ BODILY INJURY (Per accident) \$ PROPERTY DAMAGE (Per accident) \$ \$
	<input type="checkbox"/> UMBRELLA LIAB <input type="checkbox"/> OCCUR <input type="checkbox"/> EXCESS LIAB <input type="checkbox"/> CLAIMS MADE <input type="checkbox"/> DED <input type="checkbox"/> RETENTION \$						EACH OCCURRENCE \$ AGGREGATE \$ \$
B	<b>WORKERS COMPENSATION AND EMPLOYERS LIABILITY</b> ANY PROPRIETOR/PARTNER/EXECUTIVE OFFICER/MEMBER EXCLUDED? (Mandatory in NH) if yes describe under DESCRIPTION OF OPERATIONS below		N/A	BNUWC0131589	04/21/2016	04/21/2017	<input type="checkbox"/> PER STATUTE <input type="checkbox"/> OTHER E L EACH ACCIDENT \$ 1 000 0 E L DISEASE EA EMPLOYEE \$ 1 000 000 E L DISEASE POLICY LIMIT \$ 1 000,000

DESCRIPTION OF OPERATIONS / LOCATIONS / VEHICLES (ACORD 101 Additional Remarks Schedule may be attached if more space is required)

<b>CERTIFICATE HOLDER</b>  Clay County 205 Court Street West Point, MS 39773	<b>CANCELLATION</b>  SHOULD ANY OF THE ABOVE DESCRIBED POLICIES BE CANCELLED BEFORE THE EXPIRATION DATE THEREOF NOTICE WILL BE DELIVERED IN ACCORDANCE WITH THE POLICY PROVISIONS
	AUTHORIZED REPRESENTATIVE 

NO \_\_\_\_\_

**IN THE MATTER OF APPROVING TO SPREAD ON THE MINUTES THE MONTHLY  
BCAP REPORTS FOR THE MONTHS OF MAY AND JUNE 2016**

---

There came on this day for consideration the matter of approving to spread on the minutes the monthly BCAP reports for the months of May and June 2016

After motion by Lynn Horton and second by Shelton Deanes this Board doth vote unanimously to authorize to spread on the minutes the monthly BCAP reports for the months of May and June 2016 as attached hereto as Exhibit A

SO ORDERED, this the 28<sup>th</sup> day of July, 2016

A handwritten signature in black ink, appearing to be "R. B. Deane", written over a horizontal line.

President

# Monthly BCAP Report

May-16

## Direct Control

Project	Hours	Beavers	Dams
Lakw Lilly Haas	5 5	1	1
R B rd Smith	3	0	0
Hwy 50 Powell	5 5	1	0
Hwy 50 Kellogg	6 5	2	1
Hwy 50 Wooten	2	0	2
Decker rd	1	0	2
Baker rd Turner	3	0	0

## T A Survey

Hours

6 5

Location

Beasley rd, Lake Lilly rd Haas, Decker rd  
Hwy 47 Barr, Happy Hallow rd, Tomcat rd,  
Hwy 46 Williamson, Hwy 46 Murry, Colony rd  
B Ferry rd Tomlinson, B Ferry Bryant,  
Hwy 50 Pate, Tibbee Lake, Wicks rd

Report submitted by

Johnny Carter

662-803-6929

# Monthly BCAP Report

Jun-16

## Direct Control

Project	Hours	Beavers	Dams
Hwy 50 kellogg	11	2	2
Dean rd	4 5	0	1
R B rd Smith	3	1	0
Lake Lilly rd Haas	2 5	1	0
Hwy 50 Pate	1	0	1

## T A Survey

Hours

5

Location

Colony rd, CWC line rd, Beasley rd  
Boogie Bottom, Churchill st McPhearson  
McNulty rd,Pate rd, Baker rd Turner  
Lake Grove rd, Humphries Cove,  
Pointe Harbor rd, B Ferry rd Tomlinson  
B Ferry rd Bryant

Report submitted by

Johnny Carter

662 803-6929

NO \_\_\_\_\_

**IN THE MATTER OF VOIDING THE HOMESTEAD EXEMPTION  
DISALLOWANCES DUE TO DATA ENTRY ERRORS BY THE TAX  
ASSESSOR/COLLECTORS OFFICE**

---

There came on this day for consideration the matter of voiding Homestead Exemption Disallowances for year 2015 due to data entry errors by the Tax Assessor/Collector's Office

After motion by Luke Lummus and second by Shelton Deanes this Board doth vote unanimously to authorize to void the Homestead Exemption Disallowances as attached hereto as Exhibit A due to data entry errors by the Tax Assessor/Collector's office

SO ORDERED this the 28<sup>th</sup> day of July, 2016



President



Date February 21, 2016  
Letter ID L0558577280  
Period December 31, 2015  
Account # 1027-8052



AMY GRAY BERRY  
CLAY CO BOARD OF SUPERVISORS  
PO BOX 815  
WEST POINT MS 39773-0815

WRAY MERRITT WAYNE  
2974 PRUITT RD  
WEST POINT MS 397730000

Reimbursement Year 2015

Parcel# 064 33 0130000

School District West Point Consolidated School District

This is notice that the Department is making an adjustment to the County's Homestead Exemption reimbursement. The above applicant is not qualified for Homestead Exemption.

05 Applicant does not meet definition of Head of Family §27-33-13

If the applicant has any questions about an income tax debt, they may review their account information online through the Taxpayer Access Point at [www.dor.ms.gov](http://www.dor.ms.gov). If the applicant has any questions about residency status or does not have internet access, they may call 601-923-7618 for assistance.

Please complete the enclosed Notice Certification and forward to the appropriate offices as directed.

You may provide a copy of this notice to the applicant. Please note that the applicant must file any objection to this action with the Clerk of the CLAY County Board of Supervisors (Chancery Clerk's office), not the Department. The applicant has 30 days from the date of this letter to file the objection with the Clerk. If not filed in the time provided, the decision to disallow the applicant's homestead exemption is final.

Sincerely  
Tax Administrator

*on us*

Enclosure Notice Certification

*Sgt Keyed 405-50-9823 marks 2015*

*SHB 409-50-9823*

*Mr. Wray called today 3/17/16 I told him we would correct*

Homestead Notice of Adjustment



Date February 21 2016
Letter ID L1022310016
Period December 31 2015
Account # 1027-8052



AMY GRAY BERRY
CLAY CO BOARD OF SUPERVISORS
PO BOX 815
WEST POINT MS 39773-0815

LANG HELEN L
1412 PINE ACRES SUB
WEST POINT MS 397730000

Reimbursement Year 2015
Parcel# 061C304B 0030000
School District West Point Consolidated School District

This is notice that the Department is making an adjustment to the County's Homestead Exemption reimbursement. The above applicant is not qualified for Homestead Exemption.

05 Applicant does not meet definition of Head of Family §27-33-13

If the applicant has any current tax debt, they may review their account information online through the Taxpayer Access Point. If you do not have internet access, the Department will provide you with a copy of the account information.

Please complete the enclosed form.

You may provide a copy of the form to the Clerk of the County Board of Supervisors. The applicant has 30 days from the date of this notice to provide the form to the Department.

Sincerely,
Tax Administrator

Enclosure Notice Card

Handwritten notes: 443-30-2574, This is what we have, Should be 2014, On us

Mississippi Department of Revenue
Homestead Division
1(601)923-7618
Income Tax Division
1(601)923-7089

P O Box 1033 Jackson, MS 39215-1033 Phone (601) 923 7700 Fax (601) 923-7714

Form # rL0011 v95

Visit www.dor.ms.gov for tax information and online filing. If you call, please have this letter with you.



Homestead Notice of Adjustment



Date February 21 2016
Letter ID L0739292800
Period December 31 2015
Account # 1027-8052



AMY GRAY BERRY
CLAY CO BOARD OF SUPERVISORS
PO BOX 815
WEST POINT MS 39773-0815

DOSS L C
3518 PRUITT RD
WEST POINT MS 397730000

Reimbursement Year 2015

Parcel# 064 33 0050000

School District West Point Consolidated School District

This is notice that the Department is making an adjustment to the County's Homestead Exemption reimbursement. The above applicant is not qualified for Homestead Exemption.

35 Applicant or applicant's spouse has failed to comply with the income tax laws of Mississippi §27-33-63 (2)

If the applicant has any questions about an income tax debt they may review their account information online through the Taxpayer Access Point at www.dor.ms.gov. If the applicant has any questions about residency status or does not have internet access, they may call 601-923-7618 for assistance.

Please complete the enclosed Notice Certification and forward to the appropriate offices as directed.

You may provide a copy of this notice to the applicant. Please note that the applicant must file any objection to this action with the Clerk of the CLAY County Board of Supervisors (Chancery Clerk's office), not the Department. The applicant has 30 days from the date of this letter to file the objection with the clerk. If not filed in the time provided, the decision to disallow the applicant's homestead exemption is final.

Sincerely
Tax Administrator

Enclosure Notice Certification

on us

Mississippi Department of Revenue
Homestead Division
1 (601) 923-7618
Income Tax Division
1 (601) 923-7089

P O Box 1033 Jackson, MS 39215-1033 Phone (601) 923-7700 Fax (601) 923-7714

Form # rLD011 v. v95

Visit www.dor.ms.gov for tax information and online filing. If you call please have this letter with you.

Homestead Notice of Adjustment



Date June 01 2016
Letter ID L2086052224
Period December 31, 2015
Account # 1027-8052



AMY GRAY BERRY
CLAY CO BOARD OF SUPERVISORS
PO BOX 815
WEST POINT MS 39773-0815

EWELL KELVIN
602 SMITH ST
WEST POINT MS 397730000

Reimbursement Year 2015
Parcel# 083C414B 0340000

School District West Point Consolidated

This is notice that the Department is making
above applicant is not qualified for Homestead

08 Application is incomplete or inadequate

If the applicant has any questions about
the Taxpayer Access Point at www.dor.ms.gov
have internet access they may call 601-923-7700

Please complete the enclosed Notice Certification

You may provide a copy of this notice to the
action with the Clerk of the CLAY County Board of Supervisors
applicant has 30 days from the date of this
decision to disallow the applicants homestead

Sincerely,
Tax Administrator

Enclosure Notice Certification

Social is wrong
we got 687-80-3835
should be 425-25-1369
CORRECTED
on us

reimbursement The

-31 (n & r) & §27-33-41 (c)

information online through
agency status or does not

directed

file any objection to this
at the Department. The
deadline in the time provided the

# Notice Certification

Date June 01 2016  
Letter ID L2086052224  
Period December 31 2015

This certifies that the Board of Supervisors for CLAY County considered the Notice of the Department of Revenue of its disallowance of the Homestead Exemption for the below applicant. The Board entered into its minutes its determination concerning whether to accept or object to this action.

<b>Applicant Name</b>	<b>Parcel #</b>	<b>School District</b>
EWELL KELVIN 602 SMITH ST WEST POINT MS 397730000	083C414B 0340000	West Point Consolidated School District

### ***Agree and Accept***

The Board has met and entered into its minutes an order directing that the CLAY County Tax Collector re-assess and list the above property as subject to all taxes. The tax is due and payable on or before the next February 1 following the date of this notice.

***So certified and confirmed by the Clerk of the CLAY Board of Supervisors,***

Clerk \_\_\_\_\_  
(Board Clerk Signature)

The meeting of the CLAY Board of Supervisors was held \_\_\_\_\_  
(Enter date)

*If in agreement a copy of this completed document must be provided to the CLAY County Tax Collector*

### ***Disagree and Object***

The Board has met and entered into its minutes an order of its intent to file an objection with the Department of Revenue concerning this action.

***So certified and confirmed by the Clerk of the CLAY Board of Supervisors,***

Clerk \_\_\_\_\_  
(Board Clerk Signature)

The meeting of the CLAY Board of Supervisors was held \_\_\_\_\_  
(Enter date)

*If in disagreement a copy of this completed document must be provided to the Department of Revenue Office of Property Tax. A copy of the order of the Board of Supervisors providing the reason for the objection must be attached along with any documentation necessary to support the objection.*

***THIS***

***PAGE***

***LEFT***

***BLANK***

-----

Homestead Notice of Adjustment



Date June 01 2016
Letter ID L2073469312
Period December 31 2015
Account # 1027-8052



AMY GRAY BERRY
CLAY CO BOARD OF SUPERVISORS
PO BOX 815
WEST POINT MS 39773-0815

BROWN THERESA HALL
715 PERKINS ST
WEST POINT MS 397730000

Reimbursement Year 2015

Parcel# 083B211D 04000000

School District V

Social was wrong.
It has been corrected
on us

This is notice that t
above applicant is i

imbursement The

08 Application is in

) & §27-33-41 (c)

If the applicant has
the Taxpayer Acces
have internet acces

n online through
tus or does not

Please complete the

You may provide a c
action with the Clerk
applicant has 30 day
decision to disallow the applicants homestead exemption is final

ction to this

... notice, not the Department The

... this letter to file the objection with the Clerk If not filed in the time provided, the

Sincerely
Tax Administrator

Enclosure Notice Certification

# Notice Certification

Date June 01 2016  
Letter ID L2073469312  
Period December 31 2015

This certifies that the Board of Supervisors for CLAY County considered the Notice of the Department of Revenue of its disallowance of the Homestead Exemption for the below applicant. The Board entered into its minutes its determination concerning whether to accept or object to this action.

Applicant Name	Parcel #	School District
BROWN THERESA HALL 715 PERKINS ST WEST POINT MS 397730000	083B211D 0120000	West Point Consolidated School District

### Agree and Accept

The Board has met and entered into its minutes an order directing that the CLAY County Tax Collector re-assess and list the above property as subject to all taxes. The tax is due and payable on or before the next February 1 following the date of this notice.

***So certified and confirmed by the Clerk of the CLAY Board of Supervisors,***

Clerk \_\_\_\_\_  
(Board Clerk Signature)

The meeting of the CLAY Board of Supervisors was held \_\_\_\_\_  
(Enter date)

*If in agreement a copy of this completed document must be provided to the CLAY County Tax Collector*

### Disagree and Object

The Board has met and entered into its minutes an order of its intent to file an objection with the Department of Revenue concerning this action.

***So certified and confirmed by the Clerk of the CLAY Board of Supervisors,***

Clerk \_\_\_\_\_  
(Board Clerk Signature)

The meeting of the CLAY Board of Supervisors was held \_\_\_\_\_  
(Enter date)

*If in disagreement a copy of this completed document must be provided to the Department of Revenue Office of Property Tax. A copy of the order of the Board of Supervisors providing the reason for the objection must be attached along with any documentation necessary to support the objection.*

Homestead Notice of Adjustment



Date June 01 2016
Letter ID L1562108288
Period December 31 2015
Account # 1027-8052



AMY GRAY BERRY
CLAY CO BOARD OF SUPERVISORS
PO BOX 815
WEST POINT MS 39773-0815

WALKER AUDREY LYNN
18074 HWY 50 W
PHEBA MS 397550000

Reimbursement Year 2015

Parcel# 100 23 0010000

School District West Point Consolidated School District

This is notice that the Department is making an adjustment to the County's Homestead Exemption reimbursement. The above applicant is not qualified for Homestead Exemption.

08 Application is incomplete or inadequate causing eligibility to be undeterminable §27-33-31 (n & r) & §27-33-41 (c)

If the applicant has any questions about an income tax debt they may review their account information online through the Taxpayer Access Point at www.dor.ms.gov. If the applicant has any questions about residency status or does not have internet access, they may call 601-923-7700 for assistance.

Please complete

You may provide an objection with the Department. The applicant has 30 days from the date of this notice to provide a decision to disallow the exemption.

Sincerely,
Tax Administrator

Enclosure Not

Social has been connected

ed
y objection to this
Department. The
ne time provided the



on us

**Notice Certification**

Date June 01 2016  
Letter ID L1562108288  
Period December 31 2015

This certifies that the Board of Supervisors for CLAY County considered the Notice of the Department of Revenue of its disallowance of the Homestead Exemption for the below applicant. The Board entered into its minutes its determination concerning whether to accept or object to this action.

Applicant Name	Parcel #	School District
WALKER AUDREY LYNN 18074 HWY 50 W PHEBA MS 397550000	100 23 0010000	West Point Consolidated School District

**Agree and Accept**

The Board has met and entered into its minutes an order directing that the CLAY County Tax Collector re-assess and list the above property as subject to all taxes. The tax is due and payable on or before the next February 1 following the date of this notice.

***So certified and confirmed by the Clerk of the CLAY Board of Supervisors,***

Clerk \_\_\_\_\_  
(Board Clerk Signature)

The meeting of the CLAY Board of Supervisors was held \_\_\_\_\_  
(Enter date)

*If in agreement a copy of this completed document must be provided to the CLAY County Tax Collector*

**Disagree and Object**

The Board has met and entered into its minutes an order of its intent to file an objection with the Department of Revenue concerning this action.

***So certified and confirmed by the Clerk of the CLAY Board of Supervisors,***

Clerk \_\_\_\_\_  
(Board Clerk Signature)

The meeting of the CLAY Board of Supervisors was held \_\_\_\_\_  
(Enter date)

*If in disagreement a copy of this completed document must be provided to the Department of Revenue Office of Property Tax. A copy of the order of the Board of Supervisors providing the reason for the objection must be attached along with any documentation necessary to support the objection.*



Homestead Notice of Adjustment



Date June 01 2016
Letter ID L0511132032
Period December 31 2015
Account # 1027-8052



AMY GRAY BERRY
CLAY CO BOARD OF SUPERVISORS
PO BOX 815
WEST POINT MS 39773-0815

ROBERTSON OTIS
12545 LAKE GROVE RD
PRAIRIE MS 397560000

Reimbursement Year 2015
Parcel# 014 22 0060000

School District West Point Consolidated School District

This is notice that the Department is making an adjustment to the County's Homestead Exemption reimbursement. The above applicant is not qualified for Homestead Exemption.

08 Application is incomplete or inadequate, causing eligibility to be undeterminable §27-33-31 (n & r) & §27-33-41 (c)

If the applicant has any questions about an income tax debt, they may review their account information online through the Taxpayer Access Point at www.dor.ms.gov. If the applicant does not have internet access, they may call 601-923-7618 for assistance.

Please complete the enclosed Notice Certification and forward it to the Department of Revenue.

You may provide a copy of this notice to the applicant. Please advise the Clerk of the CLAY County Board of Supervisors. The applicant has 30 days from the date of this letter to file the appeal. If the applicant fails to do so, the decision to disallow the applicant's homestead exemption is final.

Sincerely,
Tax Administrator

Enclosure Notice Certification

Handwritten note: Social has been corrected \*

Handwritten note: On us

Handwritten note: this The ded the

P O Box 1033 Jackson, MS 39215-1033

Visit www.dor.ms.gov for tax information and assistance.

**Notice Certification**

Date June 01 2016  
Letter ID L0511132032  
Period December 31 2015

This certifies that the Board of Supervisors for CLAY County considered the Notice of the Department of Revenue of its disallowance of the Homestead Exemption for the below applicant. The Board entered into its minutes its determination concerning whether to accept or object to this action.

<b>Applicant Name</b>	<b>Parcel #</b>	<b>School District</b>
ROBERTSON OTIS 12545 LAKE GROVE RD PRAIRIE MS 397560000	014 22 0060000	West Point Consolidated School District

**Agree and Accept**

The Board has met and entered into its minutes an order directing that the CLAY County Tax Collector re-assess and list the above property as subject to all taxes. The tax is due and payable on or before the next February 1 following the date of this notice.

***So certified and confirmed by the Clerk of the CLAY Board of Supervisors,***

Clerk \_\_\_\_\_  
(Board Clerk Signature)

The meeting of the CLAY Board of Supervisors was held \_\_\_\_\_  
(Enter date)

*If in agreement, a copy of this completed document must be provided to the CLAY County Tax Collector*

**Disagree and Object**

The Board has met and entered into its minutes an order of its intent to file an objection with the Department of Revenue concerning this action.

***So certified and confirmed by the Clerk of the CLAY Board of Supervisors,***

Clerk \_\_\_\_\_  
(Board Clerk Signature)

The meeting of the CLAY Board of Supervisors was held \_\_\_\_\_  
(Enter date)

*If in disagreement a copy of this completed document must be provided to the Department of Revenue, Office of Property Tax. A copy of the order of the Board of Supervisors providing the reason for the objection must be attached along with any documentation necessary to support the objection.*

NO \_\_\_\_\_

**IN THE MATTER OF AUTHORIZING TRAVEL FOR CERTAIN COUNTY  
OFFICIALS AND EMPLOYEES**

---

There came on this day for consideration the matter of authorizing travel for certain county officials and employees

After motion by Lynn Horton and second by Shelton Deanes this Board doth vote unanimously to authorize and approve the County officials and employees as attached hereto as Exhibit A to travel on behalf of the conducting county business

SO ORDERED this the 28<sup>th</sup> day of July, 2016

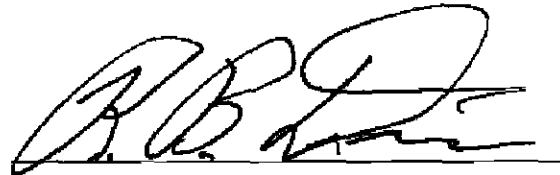
A handwritten signature in black ink, appearing to be 'A. B. Deane', written over a horizontal line.

President

**The following Employees or Elected Officials have requested authority to travel for County Business**

- Harriett Bragg, MS Justice Court Clerks Convention, Sept 6-8, 2016 at Biloxi,MS
- Sherman Ivy and Lewis Stafford to travel to quarterly Board Meeting for MS Constable Association in Gulfport, MS, Friday, July 29, 2016
- E911 Dispatchers (4) to travel to Grenada, MS, August 1-2, 2016, Public Safety Academics Class, involving Officer Involved in Shooting and responding to other critical events – Travel is 100% Reimbursed thru Dept of Public Safety
- Beth Lee, E911 Dispatcher to attend training in Philadelphia, MS, August 15-16, 2016 on Crisis and Emergency - 100% Reimbursed by Dept of Public Safety

Motion \_\_\_\_\_

Second \_\_\_\_\_

Hammett Bragg

Clay County, MS



Date of Request August 2016

To the Board of Supervisors of Clay County, MS

Destination of Travel Biloxi Ms

Dates of Travel September 6, 2016

Cost of Travel \_\_\_\_\_

Nature of Official Business Mo Justice Court clerks convention

\_\_\_\_\_  
\_\_\_\_\_  
\_\_\_\_\_

Hammett Bragg

Printed Name of Official/  
Requesting Authority to Travel

Hammett Bragg

Official or Employee Requesting  
Authority to Travel

The above form must be completed and signed prior to travel. Additionally, it must be filed with the Clerk of the Board of Supervisors to be presented to the Board for authority to travel as per Section 25-3-41 of the Mississippi Code 1972. This form must be received prior to a Board meeting to be presented to the Board of Supervisors. **The Board meets as follows** First Monday of the month, First Thursday following the First Monday, and The Fourth Thursday of the month.

It is your responsibility to make sure I received this form. If you leave the form and I am not here, please be sure to follow up with a phone call to confirm I received your request to present to the Board.

If you should have any questions, please do not hesitate to call me. Thanks!

~~Robbie Robinson~~  
Chancery Clerk



Request to travel

**MISSISSIPPI CONSTABLES ASSOCIATION**

**BOARD OF DIRECTORS**

**Glenn McKay**  
Warren County  
President

**John H Heggins**  
Warren County  
Secretary/Treasurer

**NORTHERN DISTRICT**

**Lewis Stafford**  
Clay County  
Vice President

**DIRECTORS**

**L.D Gillespie**  
Pontotoc County

**Sherman Ivy**  
Clay County

**Bobby Holloway**  
Desoto County

**CENTRAL DISTRICT**

**Jerry Dale Bridges**  
Montgomery County  
Vice President

**DIRECTORS**

**Randy Atkinson**  
Leake County

**Troy Kimble**  
Warren County

**Willie Anderson**  
Holmes County

**SOUTHERN DISTRICT**

**Harold Rhodes**  
Jefferson Davis County  
Vice President

**DIRECTORS**

**Randall Coleman**  
Simpson County

**Kelly Porter**  
Lincoln County

**Chance Curry**  
Lamar County

**SERGEANT AT ARMS**

**Terry Necaise**  
Hancock County

**DIRECTOR AT LARGE**

**CHAPLAIN**

**Christopher Coleman**  
Choctaw County

June 24, 2016

To All Board Members & Convention Committee,

We will be having our next quarterly board meeting in Gulfport It will be held on Friday, July 29, 2016 at 9 00am at the Courtyard by Marriott Beachfront If you would like to stay overnight on July 28th, we have blocked a few rooms and the MCA special room rate is \$129 00 Please make your arrangements directly with the hotel

Sincerely,

John H Heggins  
Secretary / Treasurer

**Courtyard Marriott Beachfront**  
1600 East Beach Blvd  
Gulfport, MS 39501  
Ph 228-864-4310  
Fax 228-865-0525

[http //www marriott com/gptcy](http://www.marriott.com/gptcy)

*JAV*  
*W*

I need  
these  
approved

349

1. Lynan Neely  
2  
3  
4.

OR# MSMHP0001  
Source USER  
Dest MPDAL  
Dest MDIST  
Dest MSOAL  
Control MRI1108711  
Summary AM MPDAL, MDIST MSOAL

TXT TO ALL LAW ENFORCEMENT AGENCIES  
FROM MJIC  
SUBJECT TRAINING  
WHEN AUGUST 1-2-2016  
TIME 08 00 - 17 00  
LOCATION HOST AGENCY GRENADA EOC -  
370 VAN DORN STREET, GRENADA MS

COURSE OFFICER INVOLVED SHOOTING AND CRITICAL INCIDENTS  
COURSE FOR PUBLIC SAFETY DISPATCHERS

COST \$300 00 PER STUDENT  
(ALL MAJOR CREDIT CARDS ACCEPTED)

Public Safety Academics

COURSE AVAILABLE FOR CERTIFIED E -TELECOMMUNICATORS  
THIS COURSE IS REIMBURSABLE TO MS STATE 40 HOUR CERTIFIED TELECOMMUNICATORS  
\*\*\*\* OFFICER INVOLVED SHOOTING AND CRITICAL INCIDENTS \*\*\*\*

THIS COURSE IS A (16) HOUR INTRODUCTION INTO THE INTRICACIES, EMOTIONAL TENSIONS, PROTOCOLS AND LEGAL ISSUES DURING AN OFFICER DOWN CALL, OFFICER INVOLVED SHOOTING SITUATIONS AND OTHER CRITICAL INCIDENTS WHERE THE POTENTIAL FOR INJURY OR DEATH COULD OCCUR THIS COURSE WILL ENABLE THE DISPATCHER TO HAVE ACTUAL INSIGHT ON HOW TO HANDLE SUCH CALLS FROM THE PUBLIC OR OFFICERS IN THE FIELD VIA RADIO

TOPICS OF INSTRUCTION ARE BUT NOT LIMITED TO

OFFICER DOWN EMERGENCIES, CRITICAL INCIDENTS INVOLVING  
ISSUANCE OF FELONY WARRANTS -TRAFFIC STOPS- TRAFFIC ASSISTANCE-TRAFFIC ACCIDENTS  
-DOMESTIC VIOLENCE CALLS INVOLVING ASSAULTS WITH WEAPONS-NARCOTICS-STABBINGS  
-TAKE DOWNS-SUICIDE BY COP  
DISPATCHERS MUST PREPARE THEMSELVES TO HANDLE THIS TYPE OF CRITICAL CALL, UNDERSTAND THAT TENSIONS WILL BE HIGH AND HOW TO DEAL WITH EFFECTIVELY AND PROFESSIONALLY THE STRESS AND CHAOS DURING THIS HIGH VOLUME TYPE INCIDENT

THIS COURSE WILL ENHANCE THE SKILLS NEEDED BY OFFERING CLASS ROOM INSTRUCTION, TABLE TOP EXERCISES AND ROLL PLAYING SCENARIOS  
ALL ATTENDING STUDENTS MUST PARTICIPATE IN THE ROLL PLAYING AND TABLE TOP SCENARIOS

FREE CONTINENTAL BREAKFAST AND DOOR PRIZES ARE OFFERED BOTH DAYS

COURSE IS LIMITED TO 20 STUDENTS

PLEASE CHECK BETST CALENDAR FOR ANY RESTRICTIONS

FOR HOTEL INFO AND REGISTRATION CONTACT MARIE MCCORRY 601-214-2070  
E-MAIL PSAC911@AOL COM OR QHTB911@AOL COM FAX -888-875-2466

AUTH MARIE MCCORRY VIA/MJIC OPR/HAYES

MRI 0342102 21107 0722 AT 08 40 44 06/15/16

MRI 1108711 31550 0025 AT 10 39 49 06/22/16

Reference 04N50001G7  
Msg ID 04N50001G7  
Msg Key AM  
Date/Time 20160622074137  
Ent Agcy  
Requester  
User  
ORI MS041033N  
Source USER  
Dest D1  
Dest M1069  
Control MRI1089043  
Summary AM D1, M1069

TXT \*\*\*\*\*  
CONTINUING DISPATCH EDUCATION CCOURSE WILL BE HELD SATURDAY JULY 23 2016  
AT TUPELO FIRE STATION THREE FRM 8AM TO 5 PM 902 N VETERANS TUPELO MS  
HAZMAT FOR DISPATCH YOU WILL SEE THE HAZMAT TRUCK AND EARN 1 8 HOUR ELECTIVE  
COST OF THE COURSE IS \$150.00 PER STUDENT TO REGISTER STUDENTS FAX THE NAMES  
OF THOSE ATTENDING TO 662-469-2171 ATTN BRENDA MAKE PO OR CHECK OUT TO  
SUPERIOR DISPATCH MANAGEMENT FOR FURTHER INFORMATION CONTACT 662-401-6527

THANK YOU

MRI 1089043 31551 0030 AT 07 41 37 06/22/16

*Beth*

*It is on BETST Calendar*



Retaxref / 040200000R  
b 040200000R  
Key AM  
a/T me 20150722=11444E  
AGV  
R5C=

Treva

XI + \*\* \*\* DISPATCHER TRAINING  
ON AUGUST 15 2016 AT THE GOLDEN NOON UNIT UNIT 1111111111  
COURSE "CRISIS CALL HANDLING" TRAINING CLASS FOR DISPATCHER, AND ON AUGUST 16, 2016 THERE WILL BE A 1 DAY 8 HOUR "STRESS MANAGEMENT TRAINING CLASS"  
LOCATION: THE GOLDEN NOON UNIT 1111111111  
1354 HWY 6  
PHILADELPHIA  
TIMES: 8:00 AM - 5:00 PM  
TUITION: \$150 OFF DAY - JOINTLY PROVIDED BY PHILADELPHIA POLICE DEPARTMENT  
CRISIS CALL HANDLING TOPICS WILL INCLUDE: CRISIS MANAGEMENT, DE-ESCALATION, PAK ROBBERY, ARMED AND DANGEROUS, ARMED ROBBERY, GUNNER DOWN, UNDESIRABLE CALLS, SHOOTINGS, SUICIDE INTERVENTION, COMPLAINTS, AND OTHER TOPICS.  
STRESS MANAGEMENT TOPICS WILL TEACH STUDENTS THE CAUSE AND EFFECTS OF STRESS, STRESS BURN OUT, STRESS MANAGEMENT TECHNIQUES, DEGREE OF STRESS, DISTANCE, RECOGNIZING THE SIGNS OF STRESS, HOW TO RECOGNIZE STRESS BEFORE IT BECOMES A PROBLEM, KEEPING ALL RESPONDERS SAFE AND MORE.  
FOR MORE INFORMATION OR TO REGISTER FOR THESE CLASSES, PLEASE CONTACT LAURA SPILL @ 601-23-196 OR BY EMAIL @ LAURA.SPILL@PHILADELPHIA.PA.POLICE.PA.US  
PHILADELPHIA POLICE DEPARTMENT 44 48 07 277 2

①-BL  
Beth Lee

- Need approval:
- 911 Training
  - 2 day Class - 8/15 + 8/16
  - Philadelphia, MS

NO \_\_\_\_\_

**IN THE MATTER OF AUTHORIZING PAYMENT TO THE MS DEPARTMENT OF  
EMPLOYMENT SECURITY COMMISSION FOR UNEMPLOYMENT CLAIM**

---

There came on this day for consideration the matter of authorizing payment to the MS Department of Employment Security Commission for unemployment claim

It appears to this Board as attached hereto as Exhibit A is a bill as received from the MS Department of Employment Security Commission for an unemployment claim on the said employees as attached hereto as Exhibit A, in the amount of \$1,465 38, and that the said amount should be expensed to the departmental fund and transferred to the Emergency Employment Security Account as recorded in fund #107, and paid from this fund to the MS Department of Employment Security

After motion by Lynn Horton and second by Joe Chandler this Board doth vote unanimously to authorize payment as attached hereto as Exhibit A as stated above

SO ORDERED this the 28th day of July, 2016

A handwritten signature in black ink, appearing to be 'R. B. D.', written over a horizontal line.

President

EXR-5R

Mississippi Department of Employment Security | M | D | E | S |  
REIMBURSABLE BILLING STATEMENT



Date Mailed 07/18/2016

EMPLOYER INFORMATION  
Employer Name CLAY COUNTY OFFICE OF BOARD OF SUPERVISOR MDES Employer Account Number 92-00091-0-00

THE FOLLOWING BENEFIT PAYMENTS ARE CHARGED TO YOU FOR THE SECOND QUARTER OF 2016 UNDER YOUR ELECTION TO REIMBURSE THE FUND FOR BENEFITS PAID. THIS AMOUNT IS TO BE PAID BY 09/01/2016. INTEREST ON PAST DUE BALANCES WILL ACCRUE AT THE RATE OF ONE PERCENT PER MONTH BEGINNING FORTY-SIX (46) DAYS AFTER THE DATE MAILED.

Employer Name CLAY COUNTY OFFICE OF BOARD OF SUPERVISOR		MDES Employer Account Number 92-00091-0-00			
Name	SSN	Claim End Date	Amount Charged (\$)	Prior Quarter Adjustment (\$)	Program/Entitlement
JOYCE M WASHINGTON <i>DSC</i>	<del>XXXXXXXXXX</del>	05/14/2017	220 71	0 00	REG
EDDIE C MCKINNEY	<del>XXXXXXXXXX</del>	01/09/2017	1 383 24	0 00	REG
JANET B GIBSON <i>Janet</i>	<del>XXXXXXXXXX</del>	10/31/2016	0 00	138 57	REG
<b>TOTAL</b>			<b>1,603 95</b>	<b>-138 57</b>	
<b>NET CHARGES</b>					<b>\$1,465.38</b>

To pay this debt online  
Visit [WWW.MDES.MS.GOV](http://WWW.MDES.MS.GOV)  
Select Employers  
Select Online Services for Employers  
Select Unemployment Tax Services  
Login  
Select Online Payment

# Payment Voucher

RETURN VOUCHER WITH REMITTANCE

REMIT TO MDES

P O Box 22781  
Jackson, MS 39225 2781

TOTAL PAYMENT DUE FOR  
QTR. ENDING 06/30/2016 AS OF 07/18/2016 \$1 465 38

FEIN # 646000252

Employer Name CLAY COUNTY OFFICE OF BOARD OF SUPERVISOR

92 00091 0 00 000 216 7

MDES Employer Account Number | Tax Rate | QTR/YR | Check Dgn

I certify that no part of the tax was or is to be deducted from the worker's wages.

Telephone Number

Signature of individual making return or responsible thereof

Title

Date

NO \_\_\_\_\_

**IN THE MATTER OF AUTHORIZING TO TRANSFER FUNDS**

---

There came on this day for consideration the matter of authorizing to transfer funds

It appears to this Board there are surplus funds in fund no 400, Sanitation Fund, and this Board is of the opinion these excess funds should be transferred to the fund no 001, General Fund, to be used in an efficient manner as deemed ~~necessary~~ necessary by this Board, and,

It appears to this Board that proper notice ~~was given~~ was given to the public as attached hereto as Exhibit A of the Board's intent to transfer \$100,000 of surplus funds from fund no 400, Sanitation Fund to fund no #001, General Fund

After motion by Luke Lummus and second by Lynn Horton this Board doth vote unanimously to authorize to transfer surplus funds in the amount of \$100,000 from fund no 400, Sanitation Fund to fund no 001, General Fund to be used in an efficient manner as deemed necessary by this Board

SO ORDERED this the 28th day of July, 2016

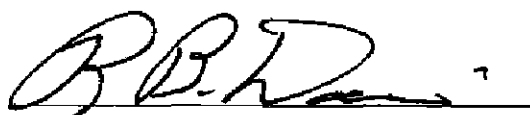

President

## NOTICE OF INTENT TO TRANSFER FUNDS

BE IT RESOLVED, Pursuant to Section 27-105-367, of the *Mississippi Code of 1972*, Notice is hereby served by the Board of Supervisors of their intent as voted upon and passed at the March 24, 2016 regular meeting to transfer surplus funds existing in the fund as listed below to be utilized by the designated fund for General Operating purposes and the said funds should be transferred accordingly, to-wit,

- #400, Sanitation Fund Transferred to #001, General County Fund, **\$100,000**

Final Ratification of the intent to transfer the said funds will be considered by the Board of Supervisors on Thursday, July 28, 2016, at 9 00 a m at the Clay County Courthouse

If any person should have any questions regarding the said transfer of surplus funds, please contact Amy Berry, Chancery Clerk at (662) 494-3124 or email at [aberry@claycounty.ms.gov](mailto:aberry@claycounty.ms.gov)

SO ORDERED this the 14<sup>th</sup> day of June, 2016

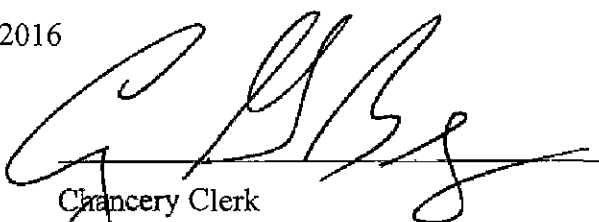

Chancery Clerk  
Clerk of the Board

### **Publish**

06/19/2016

06/26/2016

07/03/2016

07/10/2016

AFFP

Affidavit of Publication

STATE OF MISSISSIPPI] SS  
COUNTY OF CLAY]

Cindy Cannon being duly sworn, says

That she is Classified Clerk of the Daily Times Leader, a daily newspaper of general circulation, printed and published in West Point, Clay County, Mississippi, that the publication, a copy of which is attached hereto, was published in the said newspaper on the following dates

June 19, 2016

June 26, 2016

July 3, 2016

July 10, 2016

That said newspaper was regularly issued and circulated on those dates  
SIGNED

Cindy Cannon  
Classified Clerk

Subscribed to and sworn to me this 15<sup>th</sup> day of July, 2016.

Amy J Berry  
Evelyn J. Duay, DC

My Commission Expires January 6 2020

**NOTICE OF INTENT TO  
TRANSFER FUNDS**

**BE IT RESOLVED**, Pursuant to  
Section 27-105-357 of the Nevada  
Nevada Code of 1929, Nevada  
Nevada Revised Statutes, the Board of Super-  
visors of the City of Reno, Nevada  
met and discussed at the March 24,  
2016 regular meeting to transfer  
\$400,000.00 existing in the Fund  
as being held to be utilized by  
the City of Reno for General  
Operating purposes, and the said  
funds should be transferred to  
be used for the following:

**#400 - Sanitation Fund, Trans-  
ferred to #001 - General Colony  
Fund, \$100,000**

The transfer of the funds to  
be used for the said funds will be con-  
sidered by the Board of Super-  
visors on Thursday, July 28, 2016,  
at 9:00 a.m. at the City/County  
COURTHOUSE.

If any person should have any  
questions regarding the said  
transfer of funds, please  
contact Amy Berry, Chancery /

Clerk, at (775) 784-3224, or email  
at [aberry@ciorenv.com](mailto:aberry@ciorenv.com) or  
800-752-3333, ext. 3224.

**Amy BERRY**  
Chancery Clerk  
Clerk of the Court  
Reno, NV  
06/16/2016  
06/25/2016  
07/05/2016  
07/10/2016

NO \_\_\_\_\_

**IN THE MATTER OF ACCEPTING THE BID FOR THE LEASE OF HAY**

---

There came on this day for consideration the matter of accepting the bid for the Lease of Hay

It appears to this Board Notice was served to the public of sealed bids being received for a hay lease as attached hereto as Exhibit A on the 17 14 acres owned by the County as located in Section 7 Township 19 Range 16, and,

It appears the said time has come to open the bid and one bid received from Steve Portera has been received as attached hereto as Exhibit B in the amount of \$6 00 per acre

After motion by Luke Lummus and second by Lynn Horton this Board doth vote unanimously to accept and approve the said Hay Lease from Steve Portera in the amount of \$6 00 per acre beginning July 28,2016 through January 3, 2017

SO ORDERED this the 28th day of July, 2016

  
President



**NOTICE OF HAY LEASE**

**NOTICE** is hereby given to the public that the Clay County Board of Supervisors will take sealed bids on Thursday, July 28, 2016 at 9 00 a.m for the lease of lands for hay and the said lands being approximately 17 14 acres of certain real properties belonging to and located in Clay County Mississippi and situated as follows

17 14 acres of lands located in the North West Quarter of the South East Quarter of Section 7, Township 19, Range 6 located on Hwy 45 South

The land will be leased on an "As Is" condition with. The Hay Lease agreement will run from July 28, 2016 thru January 2, 2017 with no insurance responsibilities

The Board reserves the right to accept or reject any and all bids received and to waive any and all formalities with the acceptance and rejection of the bids

For further inquiries, contact Supervisor Luke Lummus at (662) 295-7037

SO ORDERED this the 6<sup>th</sup> day of June, 2016

*R. B. Davis*

**President**

**Publish**

July 22, 2016

AFFP

Affidavit of Publication

STATE OF MISSISSIPPI] SS  
COUNTY OF CLAY]

Cindy Cannon being duly sworn, says:

That she is Classified Clerk of the Daily Times Leader, a daily newspaper of general circulation, printed and published in West Point, Clay County, Mississippi, that the publication, a copy of which is attached hereto, was published in the said newspaper on the following dates

July 22, 2016  
\_\_\_\_\_  
\_\_\_\_\_  
\_\_\_\_\_

That said newspaper was regularly issued and circulated on those dates  
SIGNED

Cindy Cannon  
Classified Clerk

Subscribed to and sworn to me this 29<sup>th</sup> day of July, 2016

Amy A. Berry by Evelyn J. Gray, DC

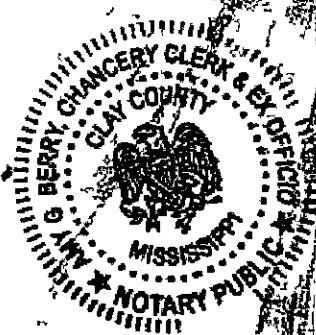

My Commission Expires January 6, 2020

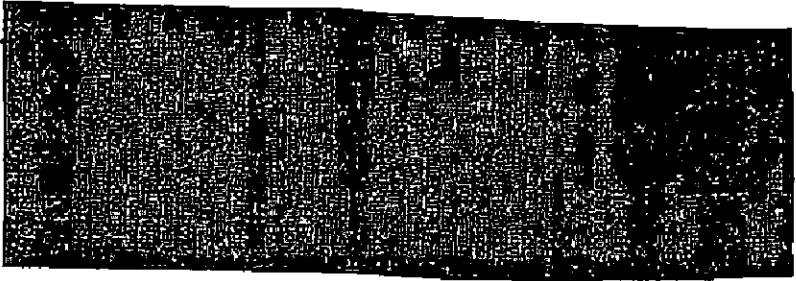



WEST POINT OFFICES  
324 Main Street - PO Box 1337  
West Point MS 39773 1337

Steve Peters

WEST POINT  
MS 39773  
JUL 17 PM 3 24  
S 8800



D, Steve Putera  
bid \$6,000 a acre  
on 17.14 acres  
North W  $\frac{1}{4}$  SE  $\frac{1}{4}$  of  
Section 7, Township  
19 N South Range 6 E



1-800-822-6344 • stjude.org

HAY LEASE

THIS LEASE is made and entered into this day by and between the CLAY COUNTY, MISSISSIPPI, acting by and through the Clay County Board of Supervisors ("Clay County" or "Lessor"), as Lessor, and STEVE PORTERA, ("Portera" or "Lessee") as Lessee,

WITNESSETH

WHEREAS, Clay County is the owner of certain real property located and situated in Clay County, Mississippi, which is generally described as 17 14 acres, more or less, in the NW ¼ SE ¼ of Section 7, Township 19N South, Range 6E Such property is further described as 25 14 acres described in a deed to Lessor in Deed Record 257 at page 174 LESS AND EXCEPT 8 0 acres leased to R W Hooks, LLC as described in Deed Record 257 at page 20, all of the land records of Clay County, Mississippi

WHEREAS, such property is currently vacant and Clay County will receive benefit by having such land in use under good husbandry practices until such time as an industrial or other commercial enterprise may purchase, lease or otherwise use such property, and

WHEREAS, the Clay County did give public notice for bids to lease such lands for the cutting of the hay thereon and received only one bid therefor, being the bid of Steve Portera in the sum of Six Dollars (\$6 00) per acre, and

WHEREAS, Clay County, at its meeting held on July 28, 2016 accepted the bid of Steve Portera as the highest and best bid to cut the hay from said property,

NOW THEREFORE, upon the terms and conditions stated herein, Clay County does hereby agree to lease to Steve Portera the property described herein upon the following terms and conditions, to-wit

1     **Premises**   The Lessor does hereby lease and rent to Lessee, and the Lessee does hereby lease and rent from the Lessor the property described in the Exhibit "A" attached hereto

2     **Purpose**     It is understood by the parties hereto, and such parties hereby agree that Lessee may use the Leased Premises solely for harvesting the hay which is growing or may grow during the term hereof and for no other purpose

3     **Term**       Unless otherwise terminated in accordance herewith, this lease shall be for a period time commencing on July 28, 2016 and terminating at midnight on January 2, 2017

4     **Rental**     The rental for such Leased Premises shall be the sum of \$6 00 per acre payable in advance, by Lessee to Lessor

5     **Use of leased premises and notice.**   Lessee's use of the leased premises is limited to periodic and customary cutting of hay Lessee shall not have the right of occupancy

of the leased premises for any other purpose. In advance of cutting the hay from the leased premises, Lessee shall give Lessor verbal notice at least three (3) days prior to cutting.

6 **Access.** Lessor shall have free access to the Leased Premises at all times during the term of this lease for purposes of showing such property to any industrial or other commercial enterprise. In exercising such access, Lessor agrees to give Lessee reasonable notice of the intent to access the property and to do so in a manner which will not infringe upon or disturb Lessee's hay cutting operations.

7 **Husbandry.** Lessee covenants with the Lessor to engage in good and acceptable husbandry practices relative to the cutting of the hay on said property.

8 **Transfer of Land.** Notwithstanding any other provision of this lease to the contrary, it is understood and agreed between the parties hereto that the Lessor shall have the right to terminate this agreement as to any portion of the Leased Premises which are sold, leased or otherwise transferred or conveyed in good faith by the Lessor for economic development purposes (a "Transfer"). However, in the event of a Transfer of any portion of the Lease Premises (the "Transferred Parcels"), Lessor shall give Lessee notice of at least sixty (60) days prior to such Transfer in order to allow Lessee the opportunity to cut any hay then growing on the leased premises. In the event of such a Transfer, Lessor shall refund to Lessee the pro-rata amount of any rent paid in advance by Lessee with respect to the Transferred Parcels effective the date Lessee returns possession of such property to Lessor.

9 **Maintenance.** Lessee shall be solely responsible for erecting and maintaining any fencing necessary for the purposes of this lease.

10. **Assignment.** Lessee agrees that it shall not assign this Agreement, or any portion hereof, without first obtaining the express written consent of Lessor.

11 **Exclusive right to cut hay.** Should the Lessee perform its obligations under this Agreement, Lessor covenants to Lessee that Lessee shall have the exclusive right to harvest the hay from the leased premises during the term of this lease.

12 **Termination.** In the event Lessor deems a material breach in the terms of this agreement to have occurred, Lessor shall give written notice to Lessee of such breach. If such breach is not cured within fifteen (15) days after such notice is given, Lessor, at its option, may terminate this lease.

13 **Liability and Indemnification.** Prior to each cutting of hay, Lessee shall make an inspection of the leased premises to insure that no hazards exist which pose a threat of injury to persons or property. By commencing cutting, Lessee acknowledges that no such hazards exist and shall release Lessor from any claims of injuries to persons or property arising out of the condition of the leased premises. Lessee shall indemnify, defend, and hold harmless Lessor from and against any and all loss or damage sustained by, liability or charges imposed on, and claims or causes of action asserted against Lessor arising in whole or in part out of or by reason of any act, omission or negligence of Lessee or its invitees, employees, affiliates, agents, representatives

or any other persons, other than Lessor, whom Lessee permits to be in, on or about the Leased Premises

14 **Tenant's Insurance** During the term of this lease, Lessee shall, at Lessee's sole cost and expense, obtain and keep in full force and effect at all times, a comprehensive general liability insurance policy to protect Lessor against any liability to the public, to any invitee of Lessee or any other person or entity incidental to Lessee's use of the Leased Premises (including, without limitation, any liability resulting from any of Lessee's cattle) or resulting from any accident occurring in or upon the Leased Premises in an amount of not less than \$1,000,000 00 for injury or death to any one person and for injury to property Lessor shall be named as an "additional insured" on such insurance, provided, however, that Lessor does not, by requiring inclusion as an additional insured, waive any provision of sovereign immunity available to Lessor Upon the request of Lessor, Lessee shall deliver to Lessor a certificate from the insurance carrier as to the insurance policy required by the paragraph

#### 15 **Miscellaneous**

(a) *Notices* All notices, demands and requests which may or are required to be given by any party hereto to another party hereto shall be in writing, and each shall be deemed to have been properly given when served personally on an executive officer of the party to whom such notice is to be given, when sent by courier receipt requested, or when sent postage prepaid by first class mail, registered or certified, return receipt requested, on the third (3rd) business day following deposit thereof, by deposit thereof in a duly constituted United States Post Office or branch thereof located in one of the states of the United States of America in a sealed envelope addressed as follows

CLAY COUNTY, MISSISSIPPI

President, Board of Trustees  
c/o Clerk of the Clay County,  
Mississippi  
P O Box 815  
205 Court Street  
West Point, Mississippi 39773

STEVE PORTERA

Mr Steve Portera  
6596 Hwy 45 Alt South  
West Point, MS 39773

Lessee and Lessor may, by notice given hereunder, designate any further or different addresses to which subsequent notices, certificates or other communications shall be sent

(b) *Severability* If any clause, provision or section of this agreement shall be to any extent adjudged, ruled or otherwise held to be invalid or unenforceable by any court of competent jurisdiction the remaining terms and provisions of this agreement shall not be affected thereby, but each term and provision of this agreement shall be valid and be enforced to the fullest extent permitted by law



(c) *Amendments* This agreement may be amended, modified and supplemented only by written agreement of all of the parties hereto

(d) *Third Party Beneficiaries* This agreement has been entered into by the parties hereto and no other person other than such parties and their respective successors and assigns, as permitted hereunder, shall acquire or have any rights under or by virtue of this agreement, except as otherwise expressly provided for herein. Nothing herein contained shall be deemed or construed by the parties hereto, nor by any third party, as creating the relationship of principal and agent or of partnership or of joint venture between the parties hereto, it being understood and agreed that no provision contained herein, nor any acts of the parties hereto, shall be deemed to create any relationship other than as landlord and tenant.

(e) *Binding Effect* All agreements, terms, provisions and conditions in this agreement shall extend and inure to the benefit of, and be binding upon, the parties hereto and their respective successors and assigns of the parties hereto

(f) *Headings / Construction* The captions and headings of this agreement are for convenience only, and are not to be construed as a part of this agreement, and shall not be construed as defining or limiting in any way the scope or intent of the provisions hereof. Whenever herein the singular number is used, the same shall include the plural and words of any gender shall include each other gender

(g) *Governing Law, Venue* This agreement shall be governed by and construed in accordance with the laws of the State of Mississippi, and venue shall lie in Clay County, Mississippi

(h) *Counterparts* This agreement may be executed in multiple counterparts or in counterpart originals, each of which taken together shall constitute one and the same instrument

(i) *Merger* This agreement represents the entire agreement between the parties hereto with respect to the matters described herein and supersedes all prior negotiations, representations or agreements

WITNESS OUR SIGNATURES, this the 10<sup>th</sup> day of September, 2016

(SIGNATURES ON FOLLOWING PAGE)



*R B Davis*  
R B Davis, President

ATTEST

*Amy G Berry*  
Amy G Berry, Chancery Clerk and  
Clerk of the Clay County Board of  
Supervisors

*Steve Portera*  
STEVE PORTERA, LESSEE

STATE OF MISSISSIPPI

COUNTY OF CLAY

Personally appeared before me, the undersigned authority in and for the said county and state, on this 9th day of September, 2016, within my jurisdiction, the within named R B DAVIS and AMY G BERRY, duly identified before me, who acknowledged that they are, respectively, the President and the Clerk of the Clay County, Mississippi, Board of Supervisors and as its act and deed, they executed the above and foregoing instrument, after first having been duly authorized by said economic development district so to do

*Amy G Berry by Evelyn J Gray, DC*  
NOTARY PUBLIC



My Commission Expires January 6 2020

STATE OF MISSISSIPPI

COUNTY OF CLAY

Personally appeared before me, the undersigned authority in and for the said county and state, on this 9th day of September, 2016, within my jurisdiction, the within named STEVE PORTERA who acknowledged that he executed the above and foregoing instrument on the day and year stated herein.

*Amy G. Berry Jay Ender J. Ender DC*  
NOTARY PUBLIC

My Commission Expires

January 6 2020



492-4059

SEPTEMBER 09, 2016

Fire Policy Status

PORTERA, STEVE  
1590 HIGHWAY 45 S  
WEST POINT MS 39773

H Ph (662)494-1071  
FIRE Policy 99-BF-V147-1 F Yr Issd 2013  
Xref YRS with SF. 3

Location: MULTIPLE LOCATIONS

Term: CONT

Type. FARM/RANCH - 3  
Coverage information  
A-DWELLING 170000  
B-PERS PROP 127500  
C-LOSS USE ACT LOSS  
D-SCD PROP 20000

Premium: 2,250.00

Renew date: JUL-20-17  
Written date. JUL-11-13  
Estimate Num: Q2K2-H8JA-6

End act 07/20/16

L-PERS LIAB 1000000  
M-MED/PERS 5000

Amount due: SFPP  
Date due: SFPP  
Bill to: SFPP

Prev prem: 3,510

Prev risk: 208,300

SFPP acct:1151-7164-09

Deductibles applied.2000 ALL PER

SEPTEMBER 09, 2016

Fire Policy Status

ADDL INSURED - SECTION II  
CLAY COUNTY MISSISSIPPI  
PO BOX 815  
WEST POINT MS 39773-0815

17.14 Acres

Section 7  
Township 19  
Range 6



Ballard Insurance  
Jamey Ballard  
P.O. 755  
421 E. Main St  
West Point, MS 39773  
662-494-1071

J Ballard 24-3161

Columbus AFD 1295

**LEFT**  
**BLANK**  
**INTENTIONALLY**

NO \_\_\_\_\_

**IN THE MATTER OF PAYING THE CLAY COUNTY CONSTABLES  
ACCORDING TO S B 2860 BASED UPON THEIR GROSS FEE INCOME**

---

There came on this day for consideration the matter of paying the Clay County, Mississippi constables according to S B 2860 based upon their gross fee income

It appears to this Board that the attached Exhibit "A" reflects the gross fee income of Constables Sherman Ivy and Lewis Stafford for the month of July 2016 as submitted by the Justice Court Clerk. It further appears that the attached Exhibit "A" represents the calculations and estimated contributions due to the Public Employees' Retirement System for each constable and the net fee income to be paid to each constable

After motion made by Shelton Deanes and second by Lynn Horton this Board doth vote unanimously to have the Chancery Clerk transfer \$566 10 to the Payroll Clearing Account to be remitted to the Public Employees' Retirement System on behalf of the Clay County constables and to pay Sherman Ivy \$1,931 26 and Lewis Stafford \$ 2,062 64 as net fee income after the Public Employees' Retirement System deduction withheld for the month of July 2016

SO ORDERED, on this the 28th day of July, 2016

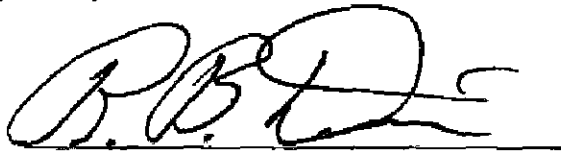
  
\_\_\_\_\_  
President

**Calculation of Estimated Contributions/Wages For Constables  
July 2016**

**Calculation**

	<b>Lewis Stafford</b>	<b>Sherman Ivy</b>	
Gross Fee Income *	\$2,355 00	\$2,205 00	<b>(Input)</b>
Minimum Withholding Rate	11%	11%	
Estimated Contributions	<u>\$259 05</u>	<u>\$242 55</u>	
Estimated Contributions	\$259 05	\$242 55	
Divided by PERS EE/ER	21 93%	21 93%	
Estimated Wages To Be Reported To PERS	<u>\$1,181 26</u>	<u>\$1,106 02</u>	
Estimated Wages	\$1,181 26	\$1,106 02	
Multipled by PERS EE Rate	9 00%	9 00%	
Estimated PERS EE Contributions	<u>\$106 31</u>	<u>\$99 54</u>	
Estimated Wages	\$1,181 26	\$1,106 02	
Multipled by PERS ER Rate	15 75%	15 75%	
Estimated PERS ER Contributions	<u>\$186 05</u>	<u>\$174 20</u>	

**\*\*Summary of Wages and Contributions to be reported to PERS For Constables \*\***

Estimated Wages	\$1,181 26	\$1,106 02	
Estimated PERS EE Contributions	\$106 31	\$99 54	205 85
Estimated PERS ER Contributions	\$186 05	\$174 20	360 25
Total Estimated Contributions	<u>\$292 36</u>	<u>\$273 74</u>	

**\*\*Funds to be Paid to Constables\*\***

Gross Fee Income	\$2,355 00	\$2,205 00
Less Total Estimated PERS EE/ER Contrib	<u>\$292 36</u>	<u>\$273 74</u>
Net Gross	\$2,062 64	\$1,931 26

Need an order to transfer to Payroll Clearing fund \$ 566 10 to remit with Retirement Contributions

\* Gross Fee Income is turned in to comptroller by the Justice Court Deputy

At the July 28, 2016, meeting of the Clay County Board of Supervisors, there came on for consideration the purchase of property which adjoins the existing area used by the Clay County jail Supervisor Lumms moved for the adoption of the following resolution, to-wit

**A RESOLUTION OF THE CLAY COUNTY, MISSISSIPPI,  
BOARD OF SUPERVISORS AUTHORIZING THE PURCHASE  
OF A VACANT LOT FROM CAROLYN V LOTT  
IN THE CITY OF WEST POINT, MISSISSIPPI**

WHEREAS, the Clay County Board of Supervisors recognizes the severe need for additional property for use by the Clay County Sheriff's department in conjunction with the Clay County jail, and

WHEREAS, Carolyn V Lott owns a vacant lot located just south of and adjoining the property currently used by the Clay County jail, such property being described as Lot 15, Block 70, Ward 3 of the A L Goodman map and survey of the City of West Point, Mississippi, and

WHEREAS, the Clay County Board of Supervisors desires to purchase such lot to provide additional needed property for the Clay County jail and such other public uses as may be desired, and

WHEREAS, an appraisal by Clay County, Mississippi, determined the value of such property to be the sum of \$4,000 00, and by letter dated June 9, 2016, such amount was offered by Clay County, Mississippi, to Mrs Lott for the purchase of such lot, a copy of such letter being attached hereto as Exhibit "A" and

WHEREAS, by letter dated June 14, 2016, Carolyn V Lott rejected such offer and advised the County that the minimum price for such lot is the sum of \$6,000 00, a copy of such letter being attached hereto as Exhibit "B", and

WHEREAS, no other suitable property is available near the Clay County jail for such purposes, and the Clay County Board of Supervisors believes it to be in the best interest of the public to purchase such lot for the sum of \$6,000 00 for the expansion of the jail property or for such other purposes as may be in the best interest of the public

THEREFORE, BE IT RESOLVED that the Clay County Board of Supervisors finds and determines that reasonable negotiations to purchase such property at the appraised value thereof have failed Further, that it is reasonable, prudent and in the best interests of the public that the County purchase such property for the sum of \$6,000 00 as an administrative settlement pursuant to the terms of §43-37-3 (c)(1) of the Mississippi Code of 1972, as amended

The motion was seconded by Supervisor Deanes Thereafter, a vote was taken with votes as follows



Supervisor R B Davis voted AYE  
Supervisor Lynn Horton voted AYE  
Supervisor Luke Lummus voted AYE  
Supervisor Shelton Deanes voted AYE  
Supervisor Joe Chandler voted AYE

The resolution was therefore unanimously adopted on this the 28<sup>th</sup> day of July, 2016

SO ORDERED on this the 28th day of July, 2016

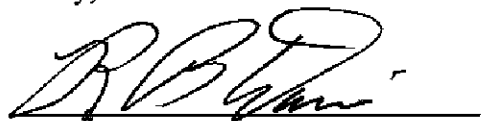
  
\_\_\_\_\_  
R. B. Davis, President

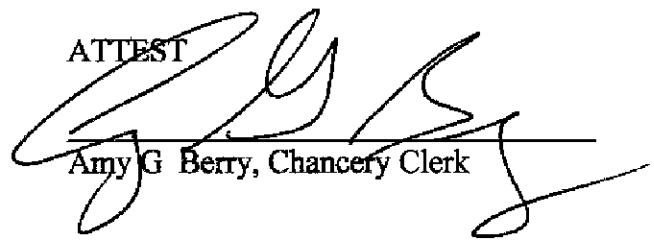
ATTEST  
  
\_\_\_\_\_  
Amy G. Berry, Chancery Clerk



# Clay County Board of Supervisors

P O Box 815  
West Point, Mississippi 39773  
Phone (662) 494-3313  
Fax (662) 492-4059  
Website [claycountymiss.com](http://claycountymiss.com)  
E mail [aberry@claycounty.ms.gov](mailto:aberry@claycounty.ms.gov)

District 1  
Lynn D Horton  
District 2  
Luke Lummus  
District 3  
R B Davis President  
District 4  
Shelton Deanes Vice  
President  
District 5  
Joe Chandler

June 9, 2016

Mrs Carolyn Lott  
605 E Main St  
West Point, MS 39773

Dear Mrs Lott

Please accept this letter as the offer of Clay County to purchase the vacant lot just south of the existing county office building This lot is generally described as Lot 15, Block 70, Ward 3 per the A L Goodman map and survey of West Point, Mississippi and is further described as Parcel No 082D115D0390000 of the tax maps of Clay County

Clay County offers to purchase this lot from you for the appraised value of \$4,000 00 per the appraisal of Stewart Stafford dated December 5, 2015 We would need a survey of the lot to establish the boundaries, and this offer is contingent on a satisfactory survey of the property

Please let me know if this offer is acceptable

Yours truly,

R B Davis, President  
Clay County Board of Supervisors

"A"

To, Clay County Board of Supervisors

From: Carolyn Lott  
605 E Main Street  
West Point, Ms  
494-1491

Date June 14 2016

Re: offer from Board of Supervisors to  
Purchase Lot South of existing County  
office building (Lot 15 Block 70, Ward 3  
of AL Goodman map)

I hereby decline your offer of Purchase for  
\$4000.00. My offer to sell the lot is  
for \$6000.00 and shall remain my Price  
The \$6000.00 will be good for 60 days.

Sincerely

Carolyn Lott

"B"

NO \_\_\_\_\_

**IN THE MATTER OF AUTHORIZING AND APPROVING THE QUOTE OF LYNDON  
MONTGOMERY TO DO ROAD REPAIRS ON MOONHEARD ROAD**

---

There came on this day for consideration the matter of authorizing and approving the quote of Lyndon Montgomery to do road repairs on Moonheard Road

It appears to this Board there are road and bridge repairs needed to be made in District 4 and Supervisor Deanes has submitted two quotes from contractors to perform the said repair work, and,

It appears to this Board the lowest and best quote of the two quotes is that of Lyndon Montgomery in the amount of \$10,500 00 to perform the said repairs on Moonheard Road

After motion by Shelton Deanes and second by Lynn Horton this Board doth vote unanimously to authorize and approve of the quote of Lyndon Montgomery and further approves the payment to him of \$10,500 00 for performing the necessary work on Moonheard Road.

SO ORDERED this the 28<sup>th</sup> day of July, 2016



President

Bid For Moonheard Road  
Albert Johnson

Road will be built up on edge of the road where erosion has washed away. Rock and dirt will be hauled in and put down for water to drain properly.

Bid For. \$16,000

Contractors Invoice

WORK PERFORMED AT

TO Clay County, Ms

Bid For Moon-Heard Road

YOUR WORK ORDER NO

OUR BID NO

BID

BID

DESCRIPTION OF WORK PERFORMED

This job will consist of digging out the ditches and redirecting the water for proper drainage. Approximately 400 yards of dirt will be hauled in to build up the road shoulder. Approximately 18 yards of 100lbs Rip Wrap will be hauled in and laid on the shoulder

Materials and Equipment Used to complete this job will be a dozer, excavator, dump truck, flagmen, and road signs

*Lydon Montgomery*

Material is guaranteed to be as specified, and the above work was performed in accordance with the drawings and specifications provided for the

above work and was completed in a substantial workmanlike manner for the agreed sum of ten thousand

five hundred Dollars (\$ 10,500.00)

is a  Partial  Full invoice due and payable by BID

in accordance with our  Agreement  Proposal

No BID

Dated

July <sup>Month</sup> 18th <sup>Day</sup>

2014 <sup>Year</sup>

TC8122

11-12

NO \_\_\_\_\_

**IN THE MATTER OF TABLING THE PURCHASE OF SLAG FROM GOLDEN  
TRIANGLE MILL SERVICES**

---

There came on this day for consideration the matter of tabling the purchase of slag from Golden Triangle Mill Services

It appears to this Board the Supervisor Deanes is requesting authority from this Board to purchase #7 slag from the Golden Triangle Mill Services at \$8 00 per ton which is significantly cheaper than the lowest bidder accepted by this Board at the first of the year with supply and material bids

After motion by Shelton Deanes and second by Lynn Horton this Board doth vote unanimously to authorize to table the said purchase pending the Board Attorney has time to review the legal aspects and to report back to the Board at the next meeting

SO ORDERD this the 28<sup>th</sup> day of July, 2016



President



## Golden Triangle Mill Services

@ Steel Dynamics  
1947 Airport Road  
Columbus, MS 39701

### 2016 Contractor Pricing

\*EAF Steel Slag Aggregate  
**Effective August 1, 2016**

<u>Item #</u>	<u>Material</u>	<u>FOB Price/Ton</u>
2788	1 ½ x 0 Duraberm	\$6 00
8098	¾ x 0 Commercial Slag	\$9 00
8099	2 x ¾ Railroad Ballast	\$9 00
8100	4 x ¾ Commercial Slag	\$8 00
8101	4 x 1 ½ Commercial Slag	\$8 00

*Prices are for material loaded on truck at our facility and do not include delivery, and are subject to change with notice*

Scale Hours 6 30 a m – 4 30 p m Monday-Friday  
Saturdays May be Scheduled Upon Request

#### **For More Information, Please Contact**

Sales John Murphy at 574-876-0466  
Email jmurphy@levyco.net

Plant (Office) 662-244-3400  
Plant (Fax) 662-244-3418



## Slag pricing at Golden Triangle Mill Services

$\frac{3}{4} \times 0$  - \$9 00 a ton

$1 \frac{1}{2} \times 0$  - \$6 00 a ton

$2 \times 3 \frac{1}{4}$  - \$9 00 a ton

$4 \times \frac{3}{4}$  - \$8 00 a ton

$4 \times \frac{1}{2}$  - \$8 00 a ton

They are going to send a formal pricing sheet to us next week

NO \_\_\_\_\_

**IN THE MATTER OF APPROVING TO ENTER INTO AN INTRA-DISTRICT  
EQUIPMENT SHARING AGREEMENT BETWEEN DISTRICT ONE, FOUR, AND  
FIVE**

---

There came on this day for consideration the matter of approving to enter into an intra-district equipment sharing agreement between District One, Four, and Five

It appears to this Board a 2015 6x4 Freightliner Tractor/Truck Model 114SD purchased at \$107,945 00 and a 2017 single axle Truck with a 7/8 yard dump bed purchased at \$75,575 00 was requested and advertised to be purchased for District Four, and

It appears to this Board Districts One, Four, and Five, are requesting to purchase and share road paving equipment to be used by the said districts in lieu of contracting with contractors to overlay and pave roads in their districts

After motion by Shelton Deanes and Lynn Horton this Board doth vote unanimously to authorize and approve to enter into an intra-district equipment sharing agreement between Districts one, four, and five on the two pieces of equipment referenced to above and further authorizes the board attorney to prepare the said agreement to be considered by this Board at the next meeting

SO ORDERED this the 28<sup>th</sup> day of July, 2016



President

12/26/2016  
16 13 03

CLAY COUNTY  
CASH DISBURSEMENTS REPORT  
FOR THE PERIOD JUNE 01 2016 TO JUNE 09 2016

PAGE 1  
APCDRPR

BANK CB CADENCE BANK- GENERAL COUNTY			--- INVOICE ---		ACCOUNT ---		AMOUNT	CHECK
CHECK	DATE	VENDOR NAME	NUMBER	LINE #	NUMBER	DESCRIPTION		AMOUNT
63619	6/01/2016	WHISPERING WOODS HOTEL	06/2016	01	001-262-476	MEALS & LODGING	545 00	545 00
63620	6/02/2016	WHISPERING WOODS HOTEL	06/2016SI	01	001-262 476	MEALS & LODGING	545 00	545 00
63621	6/03/2016	JEREMY DUBOIS	06/2016	01	001-200 476	MEALS & LODGING	205 00	205 00
63622	6/06/2016	CLAY COUNTY UNIT NAACP	06/2016	01	001-100 522	ADVERTISING RESOURCE	200 00	
			06/2016	01	001-100 522	ADVERTISING RESOURCE	200 00-	
						VOID DATE 6/06/2016		00 V
63623	6/06/2016	CLAY COUNTY UNIT NAACP	06/2016CORR	01	001-100-522	ADVERTISING RESOURCE	100 00	100 00
63805	6/09/2016	CENTER FOR GOVERNMENTAL TECH	06/2016	03	001 122 585	SEMINAR/REGISTRATION	100 00	
			06/2016	02	001-123 585	SEMINAR/REGISTRATION	50 00	
			06/2016	01	001-124 585	SEMINAR/REGISTRATION	50 00	200 00
** CHECK TOTAL FOR BANK CADENCE BANK- GENERAL COUNTY								1595 00
** TOTAL DISBURSEMENTS **								1595 00

533

12/26/2016  
16 13 12

CLAY COUNTY  
CASH DISBURSEMENTS REPORT  
FOR THE PERIOD JUNE 11 2016 TO JUNE 30 2016

PAGE 1  
APCDPR

BANK	CB	CADENCE BANK	GENERAL COUNTY	INVOICE	ACCOUNT	AMOUNT	CHECK
NUMBER	DATE	VENDOR NAME	NUMBER	LINE #	NUMBER	DESCRIPTION	AMOUNT
63806	6/13/2016	HYATT REGENCY MINNEAPOLIS	06/2016	01	001-200-476	MEALS & LODGING	1099 98
			06/2016	01	001-200 476	MEALS & LODGING	1099 98
						VOID DATE 6/30/2016	00 V
63807	6/14/2016	ANGELA TURNER-JAMES	06/2016	01	001-165 550	LEGAL FEES	350 00
							350 00
63808	6/14/2016	ATMOS ENERGY	06/2016OC	01	001 151 513	OFFICE COMPLEX BUILD	279 16
			06/2016SHER	01	001-151 514	SHERIFF S DEPT UTILI	532 59
			06/2016GENA	01	001 151 514	SHERIFF S DEPT UTILI	22 89
			06/2016DHSA	01	001-151 515	DHS BUILDING UTILITI	21 46
			06/2016D2	01	162-302 510	UTILITIES	25 76
							881 86
63809	6/14/2016	MARLIN M STEWART III	06/2016A	01	001-163-550	LEGAL FEES	902 50
			06/2016B	01	001-163-550	LEGAL FEES	475 00
							1377 50
63810	6/15/2016	PAYROLL CLEARING ACCOUNT	201605310035	01	001-000-110	PART-TIME HELP	518 02
			201605310035	02	001-000-110	STATE RET MATCHING	23 01
			201605310035	03	001-000-110	SOC SEC MATCHING	39 63
			201605310036	01	001-000 110	MEDICAL EXAMINERS PE	250 00
			201605310036	02	001-000-110	STATE RET MATCHING	39 38
			201605310036	03	001-000 110	SOC SEC MATCHING	19 13
			201605310037	01	001 000 110	OFFICE/CLERICAL	713 28
			201605310037	02	001 000 110	STATE RET MATCHING	112 34
			201605310037	03	001 000 110	SOC SEC MATCHING	52 27
			201605310039	01	001-000 110	PART TIME HELP	293 02
			201605310039	02	001-000 110	SOC SEC MATCHING	22 42
			201605310038	01	161-000 110	ROAD LABORERS-HOURLY	211 56
			201605310038	02	161-000-110	STATE RET MATCHING	33 32
			201605310038	03	161-000 110	SOC SEC MATCHING	16 18
							2343 56
63811	6/15/2016	PAYROLL CLEARING ACCOUNT	201606150002	01	001-000 110	PERSONNEL MAN/SYSTEM	873 36
			201606150002	02	001 000 110	ASST PERSONNEL MNGR	104 17
			201606150002	03	001 000 110	STATE RET MATCHING	153 97
			201606150002	04	001-000 110	SOC SEC MATCHING	72 83
			201606150002	05	001 000 110	GROUP INS MATCHING	587 89
			201606150003	01	001-000 110	OFFICE CLERICAL	918 92
			201606150003	02	001-000 110	STATE RET MATCHING	144 73
			201606150003	03	001-000 110	SOC SEC MATCHING	68 95
			201606150003	04	001-000-110	GROUP INS MATCHING	1172 48
			201606150004	01	001-000-110	DEPUTIES	1981 20
			201606150004	02	001-000-110	OFFICE CLERICAL	315 00
			201606150004	03	001-000-110	STATE RET MATCHING	361 65
			201606150004	04	001-000-110	SOC SEC MATCHING	164 11
			201606150004	05	001-000-110	GROUP INS MATCHING	1172 48
			201606150005	01	001-000-110	DEPUTIES	3160 42

534

12/26/2016  
16 13 12

CLAY COUNTY  
CASH DISBURSEMENTS REPORT  
FOR THE PERIOD JUNE 11 2016 TO JUNE 30 2016

PAGE 2  
AFCDRPR

BANK CB CADENCE BANK GENERAL COUNTY			INVOICE		ACCOUNT		CHECK	
CHECK	DATE	VENDOR NAME	NUMBER	LINE #	NUMBER	DESCRIPTION	AMOUNT	AMOUNT
			201606150005	02	001-000-110	STATE RET MATCHING	497 76	
			201606150005	03	001 000 110	SOC SEC MATCHING	226 69	
			201606150005	04	001-000-110	GROUP INS MATCHING	1758 72	
			201606150006	01	001-000-110	ASST PURCHASE CLERK	625 01	
			201606150006	02	001-000-110	STATE RET MATCHING	98 44	
			201606150006	03	001-000-110	SOC SEC MATCHING	47 81	
			201606150006	04	001-000-110	GROUP INS MATCHING	586 24	
			201606150007	01	001-000-110	RECEIVING CLERK	485 42	
			201606150007	02	001-000-110	STATE RET MATCHING	76 45	
			201606150007	03	001-000-110	SOC SEC MATCHING	37 13	
			201606150007	04	001-000-110	GROUP INS MATCHING	7 71	
			201606150008	01	001-000-110	MAINTENANCE SALARY	2477 99	
			201606150008	02	001-000-110	PART TIME HELP	138 96	
			201606150008	03	001-000-110	MAINTENANCE OVERTIME	540 74	
			201606150008	04	001-000-110	STATE RET MATCHING	497 34	
			201606150008	05	001-000-110	SOC SEC MATCHING	232 61	
			201606150008	06	001 000 110	GROUP INS MATCHING	595 60	
			201606150009	01	001 000 110	INFORMATION TECHNOLO	436 68	
			201606150009	02	001 000 110	STATE RET MATCHING	68 78	
			201606150009	03	001 000-110	SOC SEC MATCHING	32 44	
			201606150010	01	001 000 110	CASE MANAGER - GRANT	499 70	
			201606150010	02	001-000-110	OFFICE/CLERICAL	83 34	
			201606150010	03	001-000-110	STATE RET MATCHING	91 83	
			201606150010	04	001-000-110	SOC SEC MATCHING	21 18	
			201606150011	01	001-000-110	CLERICAL	1129 17	
			201606150011	02	001 000-110	STATE RET MATCHING	177 84	
			201606150011	03	001 000 110	FICA/MRDI MATCH	84 66	
			201606150011	04	001 000 110	GROUP INS MATCHING	586 24	
			201606150012	01	001 000 110	DEPUTIES	3275 19	
			201606150012	02	001 000 110	STATE RET MATCHING	515 84	
			201606150012	03	001 000-110	SOC SEC MATCHING	233 02	
			201606150012	04	001 000-110	GROUP INS MATCHING	1758 72	
			201606150013	01	001 000-110	OFFICE/CLERICAL	676 00	
			201606150013	02	001-000-110	SOC SEC MATCHING	51 71	
			201606150014	01	001-000-110	DEPUTIES	15096 14	
			201606150014	02	001-000-110	OFFICE/CLERICAL	6416 93	
			201606150014	03	001-000-110	DEPUTIES OVERTIME	1530 83	
			201606150014	04	001-000-110	OFFICE CLERICAL OVER	220 94	
			201606150014	05	001-000-110	STATE RET MATCHING	3373 38	
			201606150014	06	001-000-110	SOC SEC MATCHING	1684 51	
			201606150014	07	001 000 110	GROUP INS MATCHING	9962 81	
			201606150015	01	001-000-110	MTC TRANSPORT OFFICE	641 40	
			201606150015	02	001 000 110	STATE RET MATCHING	101 02	
			201606150015	03	001 000 110	SOC SEC MATCHING	47 71	
			201606150015	04	001 000-110	GROUP INS MATCHING	586 24	
			201606150016	01	001 000-110	JAIL ADMINISTRATOR	1666 67	
			201606150016	02	001-000-110	JAIL RECORDS CLERK	1216 42	
			201606150016	03	001-000-110	JAILORS SALARIES	8544 76	
			201606150016	04	001-000-110	KITCHEN MANAGER	1251 53	
			201606150016	05	001 000 110	JAILORS OVERTIME	1231 93	
			201606150016	06	001 000 110	STATE RET MATCHING	2191 04	

585

12/26/2016  
16 13 12

CLAY COUNTY  
CASH DISBURSEMENTS REPORT  
FOR THE PERIOD JUNE 11 2016 TO JUNE 30 2016

PAGE 3  
APCDRPR

BANK	CB	CADENCE BANK	GENERAL COUNTY	INVOICE		ACCOUNT		AMOUNT	CHECK
NUMBER	DATE	VENDOR NAME	NUMBER	LINE #	NUMBER	DESCRIPTION		AMOUNT	AMOUNT
			201606150016	07	001-000-110	SOC SEC MATCHING		1005 76	
			201606150016	08	001-000-110	GROUP INS MATCHING		8793 60	
			201606150017	01	001-000-110	DEP EMA DIRECTOR SAL		208 33	
			201606150017	02	001-000-110	STATE RET MATCHING		32 81	
			201606150017	03	001-000-110	SOC SEC MATCHING		15 47	
			201606150018	01	097-000-110	911 DIRECTOR SALARY		971 63	
			201606150018	02	097-000-110	DISPATCHERS		6471 12	
			201606150018	03	097 000-110	DISPATCHER O/T		285 83	
			201606150018	04	097 000-110	STATE RET MATCHING		1200 41	
			201606150018	05	097 000-110	SOC SEC MATCHING		552 17	
			201606150018	06	097 000-110	GROUP INS MATCHING		4103 68	
			201606150019	01	151 000-110	ROAD LABORERS- HOURL		4228 80	
			201606150019	02	151 000-110	STATE RET MATCHING		666 04	
			201606150019	03	151 000-110	SOC SEC MATCHING		290 70	
			201606150019	04	151 000-110	GROUP INS MATCHING		1758 72	
			201606150020	01	152 000-110	ROAD LABORERS- HOURL		1576 00	
			201606150020	02	152 000-110	STATE RET MATCHING		248 22	
			201606150020	03	152 000-110	SOC SEC MATCHING		120 56	
			201606150020	04	152 000-110	GROUP INS MATCHING		586 24	
			201606150021	01	153 000-110	ROAD LABORERS- HOURL		3619 80	
			201606150021	02	153-000 110	STATE RET MATCHING		473 26	
			201606150021	03	153-000-110	SOC SEC MATCHING		273 09	
			201606150022	01	154-000 110	ROAD LABORERS- HOURL		1927 20	
			201606150022	02	154-000-110	STATE RET MATCHING		303 54	
			201606150022	03	154-000-110	SOC SEC MATCHING		132 98	
			201606150022	04	154-000 110	GROUP INS MATCHING		1172 48	
			201606150023	01	155-000 110	ROAD LABORERES HOU		4250 30	
			201606150023	02	155-000 110	STATE RET MATCHING		669 42	
			201606150023	03	155 000 110	SOC SEC MATCHING		314 87	
			201606150023	04	155 000 110	GROUP INS MATCHING		1172 48	
			201606150024	01	400 000 110	SANITATION SALARY		3406 13	
			201606150024	02	400 000 110	STATE RET MATCHING		380 90	
			201606150024	03	400 000 110	SOC SEC MATCHING		403 17	
			201606150024	04	400 000 110	GROUP INS MATCHING		1758 72	
									139043 81
63812	6/15/2016	ADAPTS ELECTRONIC MONITORING	6709	01	001 163 581	HOUSING JUVENILES		133 00	
									133 00
63813	6/15/2016	SHERMAN IVY	06/2016	01	001-262-476	MEALS & LODGING		246 00	
			06/2016	02	001-262 476	MEALS & LODGING		15 95	
			06/2016	03	001 262 477	PRIVATE VEHICLE TRAV		172 80	
									434 75
63814	6/15/2016	LEWIS STAFFORD	06/2016	01	001-262 476	MEALS & LODGING		246 00	
			06/2016	02	001-262 476	MEALS & LODGING		15 95	
			06/2016	03	001-262 477	PRIVATE VEHICLE TRAV		172 80	
									434 75
63815	6/16/2016	PAYROLL CLEARING ACCOUNT	201606150025	01	001-000-110	PART TIME HELP		341 56	
			201606150025	02	001-000 110	SOC SEC MATCHING		26 13	

931

12/26/2016  
16 13 12

CLAY COUNTY  
CASH DISBURSEMENTS REPORT  
FOR THE PERIOD JUNE 11 2016 TO JUNE 30 2016

PAGE 4  
APCDRPR

BANK	CB	CADENCE BANK- GENERAL COUNTY		INVOICE			ACCOUNT		CHECK
NUMBER	DATE	VENDOR NAME	NUMBER	LINE #	NUMBER	DESCRIPTION	AMOUNT	AMOUNT	
								367 69	
63816	6/16/2016	UNEMPLOYMENT SECURITY ACCOUN	06/2016A	02	001-100 469	UNEMPLOYMENT	11 53		
			06/2016	01	155-305-469	UNEMPLOYMENT	1152 70	1164 23	
63817	6/20/2016	CALVERT-SPRADLING ENGINEERS	06/2016	01	076-602 555	ENGINEERING FEES	7152 50	7152 50	
63818	6/20/2016	DONALD SMITH COMPANY INC	06/2016	01	076 602 557	CONTRACTOR FEES	93607 30	93607 30	
63819	6/20/2016	TRUSTMARK NATIONAL BANK	06/2016A	01	231-800 802	INTEREST EXPENSE	5112 50	5112 50	
63820	6/23/2016	PAYROLL CLEARING ACCOUNT	06/2016	01	001-262-470	RET W/HELD & MATCHED	536 93	536 93	
63821	6/23/2016	SHERMAN IVY	06/2016A	01	001-262 461	CONSTABLE FEES	2342 91	2342 91	
63822	6/23/2016	LEWIS STAFFORD	06/2016A	01	001 262 461	CONSTABLE FEES	1445 16	1445 16	
63823	6/23/2016	CITY WATER & LIGHT DEPT	06/2016ELL	01	001-151 512	ELLIS CLINIC UTILITI	537 63		
			06/2016FORA	01	001-151 513	OFFICE COMPLEX BUILD	177 58		
			06/2016KXTA	01	001 151 513	OFFICE COMPLEX BUILD	454 16		
			06/2016SHERA	01	001 151 514	SHERIFF S DEPT UTILI	705 86	1875 23	
63824	6/23/2016	MS DEVELOPMENT AUTHORITY	06/2016GRAH	01	138-800-800	PRIN RETIREMENT CAP	3988 78		
			06/2016GRAH	02	138-800-802	INTEREST EXPENSE	1557 20	5545 98	
63825	6/24/2016	JEREMY DUBOIS	06/2016B	01	001 200 476	MEALS & LODGING	10 79	10 79	
63826	6/30/2016	PAYROLL CLEARING ACCOUNT	201606300002	01	001 000 110	SUPERVISORS SALARIES	16833 35		
			201606300002	02	001 000 110	PERSONNEL MAN/SYSTEM	873 36		
			201606300002	03	001 000 110	ATTORNEYS	3366 67		
			201606300002	04	001 000 110	ASST PERSONNEL MNGR	104 17		
			201606300002	05	001 000 110	STATE RET MATCHING	3335 47		
			201606300002	06	001 000 110	SOC SEC MATCHING	1564 84		
			201606300002	07	001 000-110	GROUP INS MATCHING	3522 81		
			201606300003	01	001-000-110	OFFICE CLERICAL	1075 25		
			201606300003	02	001-000-110	COMPROLLER	3664 55		
			201606300003	03	001-000-110	ATTENDING BRD MEETIN	120 00		
			201606300003	04	001-000 110	COUNTY AUDITOR	441 67		
			201606300003	05	001-000 110	COUNTY TREASURER	208 33		
			201606300003	06	001-000 110	PUBLIC SVC NOT PROV	416 67		
			201606300003	07	001-000 110	STATE RET MATCHING	933 42		

233

12/26/2016  
16 13 12

CLAY COUNTY  
CASH DISBURSEMENTS REPORT  
FOR THE PERIOD JUNE 11 2016 TO JUNE 30 2016

PAGE 5  
APCDEPR

BANK CB CADENCE BANK- GENERAL COUNTY

CHECK		INVOICE		ACCOUNT		CHECK		
NUMBER	DATE	VENDOR NAME	NUMBER	LINE #	NUMBER	DESCRIPTION	AMOUNT	AMOUNT
201606300003			08	001-000 110	SOC SEC MATCHING		438 95	
201606300003			09	001-000 110	GROUP INS MATCHING		2331 28	
201606300004			01	001 000-110	DEPUTIES		1981 20	
201606300004			02	001-000-110	OFFICE CLERICAL		315 00	
201606300004			03	001-000-110	PUBLIC SVCS NOT PROV		416 66	
201606300004			04	001 000 110	COUNTY REGISTRAR		1341 67	
201606300004			05	002-000 110	STATE FAILURES		33 33	
201606300004			06	001-000 110	ELECTION FEES		208 34	
201606300004			07	001-000 110	STATE RET MATCHING		676 65	
201606300004			08	001 000-110	SOC SEC MATCHING		305 99	
201606300004			09	001 000-110	GROUP INS MATCHING		1179 72	
201606300005			01	001-000-110	TAX ASSESSOR SALARY		4791 67	
201606300005			02	001 000 110	DEPUTIES		3160 42	
201606300005			03	001-000 110	PART-TIME HELP		296 00	
201606300005			04	001-000-110	STATE RET MATCHING		1252 45	
201606300005			05	001-000 110	SOC SEC MATCHING		608 24	
201606300005			06	001-000 110	GROUP INS MATCHING		2341 40	
201606300006			01	001 000-110	PURCHASE CLERK SALAR		416 67	
201606300006			02	001 000-110	ASST PURCHASE CLERK		208 34	
201606300006			03	001-000 110	STATE RET MATCHING		98 44	
201606300006			04	001-000 110	SOC SEC MATCHING		47 81	
201606300006			05	001-000-110	GROUP INS MATCHING		592 72	
201606300007			01	001-000 110	INVENTORY CLERK		2032 47	
201606300007			02	001-000 110	STATE RET MATCHING		320 11	
201606300007			03	001-000-110	SOC SEC MATCHING		150 01	
201606300008			01	001 000-110	RECEIVING CLERK		485 42	
201606300008			02	001-000-110	STATE RET MATCHING		76 45	
201606300008			03	001 000-110	SOC SEC MATCHING		37 13	
201606300008			04	001 000 110	GROUP INS MATCHING		6 52	
201606300009			01	001-000-110	MAINTENANCE SALARY		2834 61	
201606300009			02	001-000-110	PART-TIME HELP		64 24	
201606300009			03	001-000-110	MAINTENANCE OVERTIME		250 71	
201606300009			04	001 000-110	STATE RET MATCHING		496 06	
201606300009			05	001-000-110	SOC SEC MATCHING		231 99	
201606300009			06	001-000 110	GROUP INS MATCHING		592 72	
201606300010			01	001 000 110	INFORMATION TECHNOLO		436 68	
201606300010			02	001-000 110	STATE RET MATCHING		68 78	
201606300010			03	001-000 110	SOC SEC MATCHING		32 44	
201606300011			01	001-000-110	OFFICE/CLERICAL		647 77	
201606300011			02	001 000-110	SOC SEC MATCHING		49 55	
201606300012			01	001 000-110	BAILIFF		330 00	
201606300012			02	001-000-110	STATE RET MATCHING		34 65	
201606300012			03	001 000 110	SOC SEC MATCHING		25 25	
201606300013			01	001-000-110	CASE MANAGER GRANT		499 70	
201606300013			02	001-000 110	OFFICE/CLERICAL		83 34	
201606300013			03	001-000-110	BAILIFF/DEPUTY		165 00	
201606300013			04	001 000-110	JUDGE/REFEREE		793 29	
201606300013			05	001 000-110	STATE RET MATCHING		216 77	
201606300013			06	001-000-110	SOC SEC MATCHING		94 49	
201606300013			07	001 000 110	GROUP INS MATCHING		423 95	
201606300014			01	001 000-110	COURT ADMINISTRATOR		4041 66	

538



12/26/2016  
16 13 12

CLAY COUNTY  
CASH DISBURSEMENTS REPORT  
FOR THE PERIOD JUNE 11 2016 TO JUNE 30 2016

PAGE 6  
APCDRPR

BANK	CB	CADENCE BANK	GENERAL COUNTY	- INVOICE -		ACCOUNT	AMOUNT	CHECK
CHECK				NUMBER	LINE #	NUMBER	DESCRIPTION	AMOUNT
NUMBER	DATE	VENDOR NAME						AMOUNT
201606300014				02		001-000-110	CLERICAL	1129 17
201606300014				03		001-000-110	STATE RET MATCHING	814 40
201606300014				04		001-000-110	FICA/MEDI MATCH	386 42
201606300014				05		001-000-110	GROUP INS MATCHING	1214 62
201606300015				01		001-000-110	PROSECUTING ATTORNEY	600 00
201606300015				02		001-000-110	LUNACY JUDGE	286 15
201606300015				03		001-000-110	RETIREMENT MATCH	139 57
201606300015				04		001-000-110	FICA MATCH	42 97
201606300015				05		001-000-110	INSURANCE MATCH	729 81
201606300016				01		001-000-110	DEPUTIES	3275 19
201606300016				02		001 000 110	BAILIFF	220 00
201606300016				03		001 000 110	COUNTY JUDGES	6733 34
201606300016				04		001-000-110	STATE RET MATCHING	1585 00
201606300016				05		001 000 110	SOC SEC MATCHING	746 49
201606300016				06		001-000-110	GROUP INS MATCHING	2925 20
201606300017				01		001-000-110	CORONER S FEE	900 00
201606300017				02		001-000-110	MEDICAL EXAMINERS FE	875 00
201606300017				03		001-000-110	STATE RET MATCHING	279 56
201606300017				04		001-000-110	SOC SEC MATCHING	135 79
201606300017				05		001 000 110	GROUP INS MATCHING	10 12
201606300018				01		001 000 110	ATTORNEYS	3366 67
201606300018				02		001 000 110	STATE RET MATCHING	530 25
201606300018				03		001 000 110	SOC SEC MATCHING	257 55
201606300018				04		001 000 110	GROUP INS MATCHING	584 80
201606300019				01		001 000 110	ATTORNEYS	6180 00
201606300019				02		001 000 110	STATE RETIRE MATCHIN	973 36
201606300019				03		001 000 110	SOCIAL SEC MATCHING	455 38
201606300019				04		001 000 110	GROUP INS MATCHING	584 80
201606300020				01		001 000-110	OFFICE/CLERICAL	783 00
201606300020				02		001 000 110	ELECTION COMMISSIONER	5544 00
201606300020				03		001 000-110	STATE RET MATCHING	132 30
201606300020				04		001-000-110	SOC SEC MATCHING	479 35
201606300021				01		001-000-110	SHERIFF SALARY	7500 00
201606300021				02		001-000-110	DEPUTIES	16573 54
201606300021				03		001 000 110	OFFICE/CLERICAL	7670 92
201606300021				04		001 000-110	DEPUTIES OVERTIME	2557 50
201606300021				05		001-000-110	OFFICE CLERICAL OVER	222 94
201606300021				06		001-000-110	STATE RET MATCHING	5118 71
201606300021				07		001-000-110	SOC SEC MATCHING	2520 88
201606300021				08		001-000-110	GROUP INS MATCHING	10523 29
201606300022				01		001-000-110	MTC TRANSPORT OFFICE	962 44
201606300022				02		001 000-110	STATE RET MATCHING	44 41
201606300022				03		001 000 110	SOC SEC MATCHING	72 27
201606300023				01		001 000 110	JAIL ADMINISTRATOR	1666 67
201606300023				02		001-000-110	JAIL RECORDS CLERK	1477 96
201606300023				03		001-000-110	JAILORS SALARIES	10337 07
201606300023				04		001-000-110	KITCHEN MANAGER	1553 25
201606300023				05		001-000-110	JAILORS OVERTIME	866 82
201606300023				06		001-000-110	STATE RET MATCHING	2504 53
201606300023				07		001-000-110	SOC SEC MATCHING	1157 45
201606300023				08		001-000-110	GROUP INS MATCHING	9356 80

632

12/26/2016  
16 13 12

CLAY COUNTY  
CASH DISBURSEMENTS REPORT  
FOR THE PERIOD JUNE 11 2016 TO JUNE 30 2016

PAGE 7  
APCDRPR

BANK CB CADENCE BANK GENERAL COUNTY

--- CHECK ---		INVOICE		ACCOUNT		AMOUNT	CHECK
NUMBER	DATE	VENDOR NAME	NUMBER	LINE #	DESCRIPTION		AMOUNT
201606300024			01	001-000-110	DEP EMA DIRECTOR SAL	208	33
201606300024			02	001 000 110	STATE RET MATCHING	32	81
201606300024			03	001 000-110	SOC SEC MATCHING	15	47
201606300025			01	097-000-110	911 DIRECTOR SALARY	971	63
201606300025			02	097-000-110	DISPATCHERS	7743	59
201606300025			03	097-000-110	DISPATCHER O/T	250	06
201606300025			04	097 000 110	STATE RET MATCHING	1389	76
201606300025			05	097 000-110	SOC SEC MATCHING	639	96
201606300025			06	097 000 110	GROUP INS MATCHING	4093	60
201606300026			01	104 000-110	LAW LIBRARY ADMINIS	133	55
201606300026			02	104-000-110	STATE RET MATCHING	21	03
201606300026			03	104-000-110	SOC SEC MATCHING	9	48
201606300027			01	114-000-110	COORDINATOR/VOL FIRE	367	74
201606300027			02	114 000 110	STATE RET MATCHING	57	92
201606300027			03	114 000 110	SOC SEC MATCHING	28	13
201606300028			01	161-000 110	ROAD LABORERS-HOURLY	4084	24
201606300028			02	161 000 110	STATE RET MATCHING	643	27
201606300028			03	161 000-110	SOC SEC MATCHING	294	44
201606300028			04	161-000-110	GROUP INS MATCHING	1169	60
201606300029			01	162-000-110	ROAD LABORERS HOURL	1836	00
201606300029			02	162-000-110	STATE RET MATCHING	289	17
201606300029			03	162 000 110	SOC SEC MATCHING	140	47
201606300029			04	162 000 110	GROUP INS MATCHING	584	80
201606300030			01	163 000 110	ROAD LABORERS- HOURL	3605	76
201606300030			02	163 000-110	STATE RET MATCHING	567	90
201606300030			03	163-000-110	SOC SEC MATCHING	272	01
201606300031			01	164-000-110	ROAD LABORERS HOURL	2828	64
201606300031			02	164-000-110	STATE RET MATCHING	445	51
201606300031			03	164 000 110	SOC SEC MATCHING	194	56
201606300031			04	164 000-110	GROUP INS MATCHING	1462	00
201606300032			01	165-000 110	ROAD LABORERS HOURL	5423	46
201606300032			02	165 000-110	STATE RET MATCHING	854	19
201606300032			03	165-000-110	SOC SEC MATCHING	397	21
201606300032			04	165-000-110	GROUP INS MATCHING	1459	23
201606300033			01	400-000-110	SANITATION SALARY	4009	89
201606300033			02	400 000 110	STATE RET MATCHING	444	98
201606300033			03	400 000-110	SOC SEC MATCHING	480	38
201606300033			04	400-000-110	GROUP INS MATCHING	1751	63

249815 38

\*\* CHECK TOTAL FOR BANK CADENCE BANK- GENERAL COUNTY 513975 83

50

12/26/2016  
16 13 12

CLAY COUNTY  
CASH DISBURSEMENTS REPORT  
FOR THE PERIOD JUNE 11 2016 TO JUNE 30 2016

PAGE 8  
APCDRPR

BANK PB4 EMERGENCY EMPLOYMENT ACCOUNT

-- - CHECK -			----- INVOICE -----			ACCOUNT -		CHECK
NUMBER	DATE	VENDOR NAME	NUMBER	LINE #	NUMBER	DESCRIPTION	AMOUNT	AMOUNT
1034	6/16/2016	MS DEPT OF EMPLOYMENT SECURI	06/2016	01	107-141 469	UNEMPLOYMENT	1164 23	1164 23
** CHECK TOTAL FOR BANK EMERGENCY EMPLOYMENT ACCOUNT								1164 23

135

12/26/2016  
16 13 12

CLAY COUNTY  
CASH DISBURSEMENTS REPORT  
FOR THE PERIOD JUNE 11 2016 TO JUNE 30 2016

PAGE 9  
APCDRPR

BANK RN2 RENASANT BANK- INSURANCE ACCT

CHECK		INVOICE			ACCOUNT		AMOUNT	CHECK
NUMBER	DATE	VENDOR NAME	NUMBER	LINE #	NUMBER	DESCRIPTION		AMOUNT
1303	6/24/2016	GUARDIAN LIFE INSURANCE CO	06/2016	01	687-000 128	DUE TO GUARDIAN LIFE	890 62	
			06/2016	02	687-000-129	DUE TO GUARDIAN VISI	758 14	
			06/2016	03	687-000-130	DUE TO GUARDIAN DENT	3368 72	5017 48
1304	6/24/2016	AMERICAN FAMILY LIFE INS CO	06/2016	01	687 000-124	DUE TO AFLAC	183 45	183 45
1305	6/24/2016	COLONIAL LIFE	06/2016	01	687-000-126	DUE TO COLONIAL LIFE	52 62	52 62
1306	6/24/2016	PENNSYLVANIA LIFE INS CO	06/2016	01	687 000-122	DUE TO PENNSLVANIA L	156 62	156 62
1307	6/24/2016	ASSURITY LIFE INSURANCE CO	06/2016	01	687 000-121	DUE TO ASSURITY	45 90	45 90
1308	6/24/2016	NEW YORK LIFE	06/2016	01	687-000 123	DUE TO NEW YORK LIFE	136 24	136 24
1309	6/24/2016	LIBERTY NATIONAL INS	06/2016	01	687 000-125	DUE TO LIBERTY NATIO	2615 88	2615 88
1310	6/24/2016	LIFE INSURANCE CO OF ALABAM	06/2016	01	687 000-127	DUE TO LICOA	1392 97	1392 97
							** CHECK TOTAL FOR BANK RENASANT BANK- INSURANCE ACCT	9601 16
							** TOTAL DISBURSEMENTS **	524741 22

562

CLAY COUNTY  
PAYROLL CHECKS BY DEPT

PAGE 1

15 26 26

DEPT	CHECK #	EMPLOYEE NAME	DEPT	CHECKS
P E DATE 6/14/2016				
CHK DATE 6/15/2016 POST PD 2016/06				
0001	50436	DECKER JAMES	E	
0001	50437	EVANS WILLIE	E	
0001	50438	GARDNER STEPHEN		
0001	50439	IVY WILLIAM	C	
0001	50440	WESTBROOK ROBERT	C	
DEPARTMENT TOTALS				0001 5
0002	50441	JOHNSON LARRY		
0002	50442	JONES GRADY	W	
DEPARTMENT TOTALS				0002 2
0003	50443	COGGINS TERRY	N	
0003	50444	INMAN ANTHONY	B	
0003	50445	KEENUM WILEY	L	
0003	50446	WHITE GEORGE	R	
DEPARTMENT TOTALS				0003 4
0004	50447	FIELDS JOHN		
0004	50448	WALKER EARNEST	L	
DEPARTMENT TOTALS				0004 2
0005	50449	MCKEE ROGER	C	
0005	50450	ROBERSON SAM	L	
0005	50451	STARKS ROBERT	L	
0005	50452	THOMPSON WILLIAM	B	
0005	50453	VALENTINE TOMMIE	W	
DEPARTMENT TOTALS				0005 5
0007	50454	ALLEN GINGER	G	
0007	50455	BANKS DANNY	W	
0007	50456	BOYD LAFRANCE		
0007	50457	CUDE LESLIE	R	
0007	50458	HARRIS AVA	A	
0007	50459	HAWKINS FRANK		
0007	50460	HODGE TREVA	R	
0007	50461	JEFFERSON DENNIS	L	
0007	50462	MYERS DEBORAH		
DEPARTMENT TOTALS				0007 9
0008	50463	CHILDRESS MADISON	M	
0008	50464	JOHNSON HOPE		
0008	50465	MINOR GLORIA	J	
0008	50466	SPRAGGINS BARBARA	J	
0008	50467	WASHINGTON MORGAN		
DEPARTMENT TOTALS				0008 5
0009	50468	FROST KAY	L	
0009	50469	LANG JAMES	D	

53

P E DATE 6/14/2016  
 CHK DATE 6/15/2016 POST PD 2016/06  
 DEPT CHECK # EMPLOYEE NAME

CLAY COUNTY  
 PAYROLL CHECKS BY DEPT

DEPT	CHECK #	EMPLOYEE NAME	DEPT	CHECKS
0009	50470	LEE FORSHA	J	
DEPARTMENT TOTALS				0009 3
0012	50471	BRAGG HARRIETT	C	
0012	50472	HOLCOMBE CHRISTY	L	
0012	50473	PERRY LISA	C	
DEPARTMENT TOTALS				0012 3
0016	50474	BOWENS WILLIAM	H	
0016	50475	DEANS JOHNNY	P	
0016	50476	DOSS BILLY	R	
0016	50477	STOVALL JOHN	M	
DEPARTMENT TOTALS				0016 4
0021	50478	ALSOBROOKS JOSEPH	J	
0021	50479	BARRON LISA		
0021	50480	BENNETT KATHERINE	A	
0021	50481	BROOKS DANA		
0021	50482	EDMONDS CERITA		
0021	50483	JENNINGS DUSTON	R	
0021	50484	LEE BETH	J	
0021	50485	MITCHELL DAMIEN		
0021	50486	NEELY LYRIAN	S	
0021	50487	PARKER TERESA	L	
DEPARTMENT TOTALS				0021 10
0022	50488	ANDERSON JESSE		
0022	50489	COOK AVERY		
0022	50490	DUBOIS JEREMY		
0022	50491	HAGGARD RICHARD	A	
0022	50492	LASTER BILLY	J	
0022	50493	LEE SHAWN	C	
0022	50494	LEE STANLEY	E	
0022	50495	PETTTI BRADLEY		
0022	50496	QUINN EVERETT		
0022	50497	SCOTT TERRY	W	
0022	50498	SMITH CASSONDRA	D	
0022	50499	STRONG DEVIN	M	
0022	50500	WILLIAMS RAMIREZ	L	
DEPARTMENT TOTALS				0022 13
0023	50501	AVANT ANNIE	M	
0023	9999999	COOPERWOOD LARRY		
0023	50502	CUMMINGS JOHN	A	
0023	50503	DONALD GREGORY		
0023	50504	GOFF PATTY	L	
0023	50505	KING GENE	E	
0023	50506	LARRY REERICA	G	
0023	50507	MYLES CYNTHIA		
0023	50508	MYLES GAIL		

504

CLAY COUNTY  
PAYROLL CHECKS BY DEPT

P E DATE 6/14/2016  
CHK DATE 6/15/2016 POST PD 2016/06

DEPT	CHECK #	EMPLOYEE NAME	DEPT	CHECKS
0023	50509	RANDLE FRANK	J	
0023	50510	SYKES-COBB DEMETRIA	R	
0023	50511	TOWNSEND TIMOTHY		
0023	50512	WALKER QUEENIE		
0023	50513	WEAVER MICHAEL	A	
DEPARTMENT TOTALS				0023 14
0027	50514	FREE BARBARA		
0027	50515	FRBE MADEANA	A	
0027	50516	GARDNER DOMINIQUE		
0027	50517	HENDRIX MITZI		
0027	50518	INGRAM DEBORAH		
0027	50519	MOORE JESSE		
0027	50520	MORRIS CHRISTIE	A	
0027	50521	SANDERS ELOISE		
0027	50522	WASHINGTON TONY	R	
0027	9999999	WEAVER CHELSEI		
0027	50523	WILLIAMSON FRANK	E	
0027	50524	WILLIAMSON JOSEPH		
DEPARTMENT TOTALS				0027 12
0028	50525	HEADD HAL	C	
DEPARTMENT TOTALS				0028 1
TOTAL CHECKS				92

555

P E DATE 6/14/2016  
CHK DATE 6/15/2016 POST FD 2016/06  
DEPT CHECK # EMPLOYEE NAME  
0007 50526 HAMPTON SIDNEY

CLAY COUNTY  
PAYROLL CHECKS BY DEPT

PAGE 1  
9 26 09

DEPT	CHECKS
0007	1
DEPARTMENT TOTALS	
0007	1
TOTAL CHECKS	1

506



P E DATE 6/30/2016  
 CHK DATE 6/30/2016 POST PD 2016/06

CLAY COUNTY  
 PAYROLL CHECKS BY DEPT

DEPT	CHECK #	EMPLOYEE NAME	DEPT	CHECKS
0001	50544	DECKER JAMES	E	
0001	50545	EVANS WILLIE	E	
0001	50546	GARDNER STEPHEN		
0001	50547	HORTON LYNN	D	
0001	50548	IVY WILLIAM	C	
0001	50549	WESTBROOK ROBERT	C	
		DEPARTMENT TOTALS	0001	6
0002	50550	JOHNSON LARRY		
0002	50551	JONES GRADY	W	
0002	50552	LUMMUS OSCAR	W	
		DEPARTMENT TOTALS	0002	3
0003	50553	DAVIS R	B	
0003	50554	INMAN ANTHONY	B	
0003	50555	KEENUM WILEY	L	
0003	50556	WHITE GEORGE	R	
		DEPARTMENT TOTALS	0003	4
0004	50557	DEANES SHELTON	L	
0004	50558	FIELDS JOHN		
0004	50559	WALKER EARNEST	L	
		DEPARTMENT TOTALS	0004	3
0005	50560	CHANDLER JOE	D	
0005	50561	MCKEE ROGER	C	
0005	50562	ROBERSON SAM	L	
0005	50563	STARKS ROBERT	L	
0005	50564	THOMPSON WILLIAM	B	
0005	50565	VALENTINE TOMMIE	W	
		DEPARTMENT TOTALS	0005	6
0007	50566	ALLEN GINGER	G	
0007	50567	BANKS DANNY	W	
0007	50568	BERRY AMY	G	
0007	50569	BOYD LAFRANCE		
0007	50570	CARTER ALVIN		
0007	9999999	COX REBECCA	W	
0007	50571	CUDE LESLIE	R	
0007	50572	EASTERLING MICHELLE	D	
0007	50573	GREEN JOHN	F	
0007	50574	HARRIS AVA	A	
0007	50575	HAWKINS FRANK		
0007	50576	HODGE TREVA	R	
0007	50577	JEFFERSON DENNIS	L	
0007	50578	MARSHALL ROBERT	B	
0007	50579	MCCNAMEE DANNY		
0007	50580	MYERS DEBORAH		
0007	50581	ROSS HARRY	S	
0007	50582	STEWART MARLIN	M	

CU  
 2

CLAY COUNTY  
PAYROLL CHECKS BY DEPT

PAGE 2

P E DATE 6/30/2016  
CHK DATE 6/30/2016 POST PD 2016/06

14 44 53

DEPT	CHECK #	EMPLOYEE NAME	DEPT	CHECKS
0007	50583	STOREY THOMAS	B	
0007	50584	WILLIAMS KRISTEN	W	
0007	50585	YORK WESLEY	A	
DEPARTMENT TOTALS				0007 21
0008	50586	CHILDRESS MADISON	M	
0008	50587	HARRELL ROBERT	D	
0008	50588	JOHNSON HOPE		
0008	50589	MINOR GLORIA	J	
0008	50590	SPRAGGINS BARBARA	J	
0008	50591	WASHINGTON MORGAN		
DEPARTMENT TOTALS				0008 6
0009	50592	FROST KAY	L	
0009	50593	LAMKIN PAMELA	P	
0009	50594	LANG JAMES	D	
0009	50595	LEE PORSHA	J	
0009	50596	PITTS ALICE	S	
DEPARTMENT TOTALS				0009 5
0011	50597	BREWER MAR	W	
0011	50598	BRYAN THOMAS	D	
0011	50599	CASTON GEORGE	H	
0011	50600	IVY LINDA		
0011	50601	WALKER SAWANA		
DEPARTMENT TOTALS				0011 5
0012	50602	BRAGG HARRIETT	C	
0012	50603	HAMPTON THOMAS	E	
0012	50604	HOLCOMBE CHRISTY	L	
0012	50605	MCBRAYER CHRIS	R	
0012	50606	PERRY LISA	C	
0012	50607	TOLLIVER CHARLES	H	
DEPARTMENT TOTALS				0012 6
0015	50608	MCCLINTON BRANDON	J	
DEPARTMENT TOTALS				0015 1
0016	50609	BOWENS WILLIAM	H	
0016	50610	DEANS JOHNNY	P	
0016	50611	DOSS BILLY	R	
0016	50612	STOVALL JOHN	M	
DEPARTMENT TOTALS				0016 4
0021	50613	ALSOBROOKS JOSEPH	J	
0021	50614	BARRON LISA		
0021	50615	BENNETT KATHERINE	A	
0021	50616	BROOKS DANA		

508

CLAY COUNTY  
PAYROLL CHECKS BY DEPT

P E DATE 6/30/2016  
CHK DATE 6/30/2016 POST PD 2016/06

DEPT	CHECK #	EMPLOYEE NAME	DEPT	CHECKS
0021	50617	EDMONDS CERITA		
0021	50618	JENNINGS DUSTON	R	
0021	50619	LEE BETH	J	
0021	50620	MITCHELL DAMIEN		
0021	50621	NEELY LYRIAN	S	
0021	50622	PARKER TERESA	L	
0021	50623	WALKER COURTNEY	L	
DEPARTMENT TOTALS				0021 11
0022	50624	ANDERSON JESSE		
0022	50625	COOK AVERY		
0022	50626	DUBOIS JEREMY		
0022	50627	HAGGARD RICHARD	A	
0022	50628	HORNER BOBBY	N	
0022	50629	LASTER BILLY	J	
0022	50630	LEE SHAWN	C	
0022	50631	LEE STANLEY	E	
0022	50632	PETTIT BRADLEY		
0022	50633	PONDS CHRISTOPHER	R	
0022	50634	QUINN EVERETT		
0022	50635	SCOTT HARVEY	E	
0022	50636	SCOTT FERRY	W	
0022	50637	SMITH CASSONDRA	D	
0022	50638	STRONG DEVIN	M	
0022	50639	WILLIAMS RAMIREZ	L	
DEPARTMENT TOTALS				0022 16
0023	50640	AVANT ANNIE	M	
0023	9999999	COOPERWOOD LARRY		
0023	50641	CUMMINGS JOHN	A	
0023	50642	DONALD GREGORY		
0023	50643	GOFF PATTY	L	
0023	50644	KING GENE	E	
0023	50645	LARRY REERICA	G	
0023	50646	MYLES CYNTHIA		
0023	50647	MYLES GAIL		
0023	50648	RANDLE FRANK	J	
0023	9999999	ROBINSON GARRETT		
0023	50649	SYKES-COBB DEMETRIA	R	
0023	50650	TOWNSEND TIMOTHY		
0023	50651	WALKER QUEENIE		
0023	50652	WEAVER MICHAEL	A	
DEPARTMENT TOTALS				0023 15
0027	50653	EDWARDS APRIL	M	
0027	50654	FREE BARBARA		
0027	50655	FREE MADEANA	A	
0027	50656	GARDNER DOMINIQUE		
0027	50657	HENDRIX MITZI		
0027	50658	INGRAM DEBORAH		
0027	50659	IRIONS DANIEL	L	
0027	50660	MOORE JESSE		

509

P E DATE 6/30/2016  
CHK DATE 6/30/2016 POST PD 2016/06

CLAY COUNTY  
PAYROLL CHECKS BY DEPT

DEPT	CHECK #	EMPLOYEE NAME	DEPT	CHECKS
0027	50661	MORRIS CHRISTIE	A	
0027	50662	SANDERS ELOISE		
0027	50663	WASHINGTON TONY	R	
0027	50664	WEAVER CHELSEI		
0027	50665	WILLIAMSON FRANK	E	
0027	50666	WILLIAMSON JOSEPH		
		DEPARTMENT TOTALS	0027	14
0028	50667	HEADD HAL	C	
		DEPARTMENT TOTALS	0028	1
		TOTAL CHECKS		127

009

|

				CLAY COUNTY	
				PAYROLL CHECKS BY DEPT	
DEPT	CHECK #	EMPLOYEE NAME		DEPT	CHECKS
P E DATE	6/30/2016				
CHK DATE	6/30/2016	POST PD	2016/06		
0007	50671	BERRY	AMY	G	
0007	50672	HAMPTON	SIDNEY		
		DEPARTMENT TOTALS		0007	2
0028	50673	HEADD	HAL	C	
		DEPARTMENT TOTALS		0028	1
				TOTAL CHECKS	3

1 9

P E DATE 6/30/2016  
CHK DATE 6/30/2016 POST PD 2016/06  
DEPT CHECK # EMPLOYEE NAME  
0012 50676 IVY SHERMAN  
0012 50677 STAFFORD CHARLES

CLAY COUNTY  
PAYROLL CHECKS BY DEPT

PAGE 1

9 29 32

DEPT CHECKS  
L

DEPARTMENT TOTALS 0012 2

TOTAL CHECKS 2

709

NO \_\_\_\_\_

**IN THE MATTER OF REQUESTING TO GO INTO CLOSED SESSION**

---

There came on this day for consideration the matter of requesting to go into closed session

After motion by Lynn Horton and second by Shelton Deanes this Board doth vote unanimously to go into closed session

SO ORDERED this the 28<sup>th</sup> day of July, 2016



President

NO \_\_\_\_\_

**IN THE MATTER OF GOING FROM CLOSED SESSION TO EXECUTIVE SESSION  
AS ALLOWED UNDER SECTION 25-41-7 OF THE MISSISSIPPI CODE**

---

There came on this day for consideration the matter of going from closed session to executive session as allowed under Section 25-41-7 of *the Mississippi Code*

After motion by Shelton Deanes and second by Lynn Horton this Board doth vote unanimously to go from closed session to executive session as allowed under Section 25-41-7 of the Mississippi Code of 1972 to discuss a security issue, potential litigation matter, and the performance and evaluation of an employee

SO ORDERED this the 28<sup>th</sup> day of July, 2016



President

NO \_\_\_\_\_

**IN THE MATTER OF COMING OUT OF EXECUTIVE SESSION**

---

There came on this day for consideration the matter of coming out of Executive Session  
After motion by Shelton Deanes and second by Lynn Horton this Board doth vote  
unanimously to authorize to come out of executive session

SO ORDERED this the 28<sup>th</sup> day of July, 2016

A handwritten signature in black ink, appearing to be "B. B. Deanes", written over a horizontal line.

President



NO \_\_\_\_\_

**IN THE MATTER OF APPROVING THE MINUTES FROM THE PUBLIC HEARING  
HELD ON THE HOME PROJECT GRANT APPLICATION**

---

There came on this day for consideration the matter of approving the minutes from the Public Hearing held on the Home Project Grant Application

It appears to this Board notice was given as attached hereto as Exhibit A on a hearing being held on the submission of a HOME Project Grant Application for year 2016 and the said hearing was held on Thursday, July 28, 2016 at 10 00

After motion by Shelton Deanes and second by Luke Lummus this Board doth vote unanimously to authorize to approve of the said minutes as attached hereto as Exhibit A on the hearing held Thursday, July 28, 2016, at 10 00 in the Clay County Board meeting room

SO ORDERED this the 28<sup>th</sup> day of July, 2016



President

After motion by Shelton Deanes and second by Lynn Horton this Board doth vote unanimously to adjourn until Monday, August 1, 2016 at 9 00 a m

SO ORDERED this the 28<sup>th</sup> day of July, 2016



President

AFFP

Affidavit of Publication

STATE OF MISSISSIPPI] SS  
COUNTY OF CLAY]

Cindy Cannon being duly sworn, says

That she is Classified Clerk of the Daily Times Leader, a daily newspaper of general circulation, printed and published in West Point, Clay County, Mississippi, that the publication, a copy of which is attached hereto, was published in the said newspaper on the following dates

July 12, 2016

\_\_\_\_\_

\_\_\_\_\_

\_\_\_\_\_

That said newspaper was regularly issued and circulated on those dates  
SIGNED

Cindy Cannon  
Classified Clerk

Subscribed to and sworn to me this 12 day of July, 2016.

Amy H. Bailey By Ava J. Harris, DC

My Commission Expires January 6, 2020

## **PUBLIC HEARING NOTICE FOR INITIAL HEARING**

### **Homeowner Rehabilitation/Reconstruction**

The Clay County Board of Supervisors is considering applying to Mississippi Home Corporation for funding through the HOME Investment Partnership Program—Homeowner Rehabilitation/Reconstruction. The State of Mississippi has allocated \$3,427,477 that will be made available to cities and counties on a competitive basis to undertake homeowner rehabilitation/reconstruction activities.

The activities for which these funds may be used are in areas of affordable housing for low and very low-income persons. More specific details regarding eligible activities, program requirements, and the rating system will be provided at a public hearing which will be held at the Clay County Courthouse, 205 Court St., West Point, MS, on July 28, 2016 at 10:00 a.m.

The purpose of this hearing will be to obtain citizen input into the development of the application. The location for this hearing is an accessible facility. All comments are welcome and must be submitted in writing. If a translator is needed for non-English speaking persons, please contact Spencer Brooks at 662-320-2009 at least 5 days prior to the meeting in an effort to accommodate this request.

Clay County does not discriminate on the basis of disability in the admissions or access to or treatment or employment in its programs or activities.

**CLAY COUNTY  
FY 2016 HOME PUBLIC HEARING  
CLAY COUNTY COURTHOUSE  
WEST POINT, MISSISSIPPI**

July 28, 2016  
10 00 AM

Name	Address	Telephone
B.B. Law	W.P.	295-1874
P.O. Borcht	West Point, MS 39773	494 3124
J. Deane	CCSO	494 3124
J. Smith	W.P.	295 2323
L. L.	720 Lumen Rd	295 7037
Shirley Thomas	94 Webster rd W.P.	295 6110
Joe Chandler	2773 Davis Rd Mobern	295 3240
B. Marshall	1407 <del>State</del> Grove Rd West Point MS 39773	494 -5184
Brian Jones	475 College St Columbus MS 39701	329 1741
Alex Hollency	Columbus	328 2971
Sue Brown	GTPDD	320 2009
H. H. [unclear]	GTPDD, Inc.	324 7860
[unclear]	DTL	494 1422
Phyllis Benson	etpdd	320-2001

Minutes of Initial Public Hearing  
Clay County, Mississippi  
2016 HOME Grant Application  
July 28, 2016

The Clay County Board of Supervisors held a public hearing on July 28, 2016 at 10 00 AM in the Clay County Courthouse. The purpose of this hearing was to obtain input from local citizens in the development of an application to the Mississippi Home Corporation (MHC) for HOME grant funds.

Mr. Spencer Brooks, Project Administrator from Golden Triangle Planning and Development District, was present and explained the application process and rating factors for this grant program. They stated that the Mississippi Home Corporation has approximately \$3.4 million in funds from the U.S. Department of Housing and Urban Development for homeowner rehabilitation/reconstruction which will be made available to local units of government through a competitive application process. They also stated that the grant applications are due at the MHC office in Jackson no later than 3:00 PM on August 19, 2016.

The program changes were highlighted to those in attendance, emphasizing that the application being submitted was a Phase I Application, and that no homeowner selection was taking place at this time. The attendees were given information on the Phase I process, and that if the application ranked high enough, a Phase II Application would be requested. Once a Phase II Application was requested, then homeowner selection would begin. The areas with the highest percentage of monthly owner costs would receive first priority. Also, the focus would be more on rehabilitation, rather than reconstruction.

The administrator asked if there were any questions or comments from the attendees.

There being no further questions or comments, the hearing was adjourned.

A roster of those attending is attached.

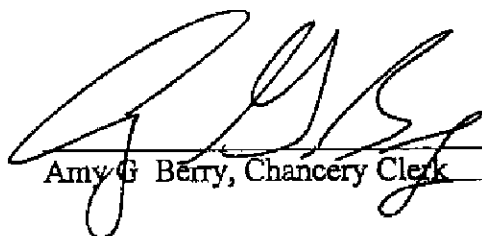
  
\_\_\_\_\_  
Amy G. Berry, Chancery Clerk

  
\_\_\_\_\_  
R. B. Davis, President

