

**Minutes of
Clay County Board of Supervisors
Regular Meeting
Tuesday, July 6, 2021 at 9:00 a.m.**

BE IT REMEMBERED a regular meeting of the Clay County Board of Supervisors was held at the Clay County Courthouse, West Point, Mississippi, on Tuesday, July, 6, 2021.

PRESENT:

Lynn D. Horton, Supervisor District 1
Luke Lummus, Supervisor District 2
R. B. Davis, Supervisor District 3
Shelton Deanes, Supervisor District 4, Presiding
Joe Chandler, Supervisor District 5

Amy G. Berry, Chancery Clerk
Angela Turner Ford, Board Attorney
Eddie Scott, Clay County Sheriff

County Residents

The following proceedings were had:

CALL TO ORDER/INVOCATION

The meeting was called to order by Sheriff Eddie Scott. The welcome was given by Supervisor Deanes with the invocation given by Supervisor Luke Lummus.

ADOPTION OF AGENDA

Supervisor Davis moved to adopt the agenda as presented.

The motion was seconded by Supervisor Lummus.

(Exhibit "A")

AMENDMENT OF AGENDA

Supervisor Horton moved to amend the agenda as presented.

The motion was seconded by Supervisor Chandler.

AMMENDMENTS TO BE APPROVED AND ADDED TO THE AGENDA

The amendments to be added to the agenda for further consideration and discussion were as follows:

- Supervisor Davis requested consideration of the Petition of Gertrude Gaskin
- John Smith requested to speak to the Board on W. TVA Road
- Angela Turner Ford regarding an Executive Session matter
- Sheriff Eddie Scott requesting two quotes for the Board's consideration and an Executive Session Personnel Matter

AUTHORIZE AND APPROVE THE CLAIMS DOCKET FOR THE MONTH OF JULY 2021

Supervisor Horton moved to authorize and approve the Claims Docket for payment for the month of July 2021.

The motion was seconded by Supervisor Davis.

(Exhibit "B")

AUTHORIZE AND APPROVE PAYMENT TO RANDY JONES FOR FLOOD PLAIN COORDINATOR SERVICES IN THE AMOUNT OF \$1,144.40

Supervisor Lummus moved to authorize and approve payment to Randy Jones for Flood Plain Coordinator services in the amount of \$1,144.40.

The motion was seconded by Supervisor Davis.

(Exhibit "C")

AUTHORIZE AND APPROVE TO GRANT A THIRTY DAY EXTENSION FOR THE REAL AND PERSONAL PROPERTY ROLL FOR YEAR 2021 PENDING APPROVAL FROM THE MS DEPARTMENT OF REVENUE

Supervisor Lummus authorized and approved to grant a thirty-day extension for the Real and Personal Property Roll for year 2021 due to the medical issues of the County's Appraiser and for the said approval to be granted pending approval by the MS Department of Revenue.

The motion was seconded by Supervisor Davis.

(Exhibit "D")

AUTOHRIZE AND APPROVE TO RESCIND THE REQUEST GRANTING PLUM CREEK THE REAL PROPERTY EXEMPTOIN DUE TO THE APPLICATION NOT BEING ELLIGIBLE

Supervisor Lummus to authorize and approve to rescind the action taken by the Board granting the Real Property exemption to Plum Creek Environmental Technologies LLC due to the application ineligibility during this calendar year. The Tax Assessor/Collector stated the applicants would be eligible for property exemptions any time after the January 1st following the date of purchase/acquisition.

The motion was seconded by Supervisor Davis.

AUTHORIZE AND APPROVE TO GRANT THE INDUSTRIAL EXEMPTION REQUEST FOR FABRICATOR SUPPLY ON PERSONAL PROPERTY IN THE AMOUNT OF \$750,000

Supervisor Horton authorized and approved to grant the Industrial Exemption Request of Fabricator Supply on Personal Property in the amount of \$750,000.

The motion was seconded by Supervisor Chandler.

(Exhibit "E")

AUTHORIZE AND APPROVE JUGE MCBRAYER TO TRAVEL TO BILOXI, MS TO THE GOLDEN NUGGET FOR THE MS ASSOCIATION OF JUSTICE COURT JUDGES SUMMER CONVENTION

Supervisor Davis moved to authorize and approve Judge McBrayer to travel to Biloxi, MS to the Golden Nugget for the MS Association of Justice Court Judges Summer Convention.

The motion was seconded by Supervisor Horton.

(Exhibit "F")

AUTHORIZE AND APPROVE THE COUNTY ATTORNEY TO PURCHASE THREE LICENSES FOR DROP BOX-BUSINESS, A CLOUD BASED SOFTWARE, TO BETTER FACILITATE CASE MANAGEMENT NEEDS FOR COURT

Supervisor Horton moved to authorize and approve the County Attorney to purchase three (3) licenses for Drop Box-Business, a cloud-based software, to better facilitate case management needs for court with defense attorneys.

The motion was seconded by Supervisor Davis.

(Exhibit "G")

AUTHORIZE AND APPROVE FOR INTEGRATED SOLUTIONS TO TRANSFER THE OLD RADIOS TO THE NEW CARS FOR \$1,358

Supervisor Lummus moved to authorize and approve for Integrated Solutions to transfer the old radios to the new Sheriff cars for \$1,358.00

The motion was seconded by Supervisor Horton.

(Exhibit "H")

AUTHORIZE AND APPROVE TO REPLACE THE HEAT PUMP IN THE AIR CONDITIONING UNIT AT THE HENRY HARRIS BUILDING LOCATED ON COURT STREET

Supervisor Horton moved to authorize and approve to replace the heat pump in the Air Conditioning Unit for a cost of \$2,269.00 at the Henry Harris Building located on Court Street.

The motion was seconded by Supervisor Davis.

(Exhibit "I")

AUTHORIZE AND APPROVE MATERIALS AND LABOR TO REPAIR FRONT END OF 2016 CHARGER AT A COST OF \$1,969.00

Supervisor Horton moved to authorize and approve payment for materials and labor in the amount of \$1,969.00 to repair front end of 2016 charger of C24.

The motion was seconded by Supervisor Chandler.

(Exhibit "J")

AUTHORIZE AND APPROVE PAYMENT FOR INVOICE TO SCALES BIOLOGICAL LABORATORY, INC FOR DNA TESTING ON CIRCUIT COURT

Supervisor Horton moved to authorize and approve payment for invoice to Scales Biological Laboratory, Inc for DNA Testing on Circuit Court in the amount of \$6,167.00.

The motion was seconded by Supervisor Lummus.

(Exhibit "K")

AUTHORIZE AND APPROVE JIMMY MCKEE TO SIGN TICKETS UP TO \$500.00 WITHOUT OBTAINING A PURCHASE ORDER

Supervisor Lummus moved to authorize and approve for Jimmy McKee, building and grounds employee, to sign tickets totaling up to \$500.00 without obtaining a purchase order.

The motion was seconded by Supervisor Davis.

(Exhibit "L")

AUTHORIZE AND APPROVE THE SHERIFF TO APPLY FOR A GRANT WITH THE FOUR COUNTY FOUNDATION IN THE AMOUNT OF \$10,000

Supervisor Lummus moved to authorize and approve for the Sheriff to apply for a grant with the Four County Foundation in the amount of \$10,000 to assist with Sheriff's Deputy getting Pilot license to fly the drones.

The motion was seconded by Supervisor Davis.

(Exhibit "M")

AUTHORIZE AND APPROVE FOR THE SHERIFF, JAIL ADMINISTRATOR, JAIL RECORDS CLERK, AND TWO BOARD OF SUPERVISOR MEMBERS TO TRAVEL TO THE AMERICAN CORRECTIONAL ASSOCIATION CONFERENCE IN NASHVILLE, TN

Supervisor Lummus moved to authorize and approve for the Sheriff, Jail Administrator, Jail Records Clerk, and two Board of Supervisor Members to travel to the American Correctional Association Conference in Nashville, TN, August 12-16, 2021.

The motion was seconded by Supervisor Davis.

(Exhibit "N")

AUTHORIZE AND APPROVE THE BOARD ATTORNEY TO SEND A LETTER TO THE LANDOWNER ADJACENT TO MRS. GERTRUDE GASKIN MAKING THEM AWARE OF THE STATUTORY REQUIREMENTS OF MAINTAINING THEIR PROPERTY

Supervisor Davis moved to authorize and approve for the Board Attorney to send a letter to the landowner adjacent to Mrs. Gertrude Gaskin making them aware of the statutory requirements relative to maintaining their property.

The motion was seconded by Supervisor Lummus.

(Exhibit "O")

AUTHORIZE AND APPROVE TO SERVE NOTICE TO A LANDOWNER LIVING ON HERMAN SHIRLEY ROAD TO CLEAN THE PROPERTY OR A HEARING WILL BE HELD

Supervisor Lummus moved to authorize and approve for the Board Attorney to serve notice to a Landowner living on Herman Shirley Road to clean the property or a hearing will be held.

The motion was seconded by Supervisor Davis.

AUTHORIZE AND APPROVE TO GO INTO CLOSED SESSION

Supervisor Lummus moved to go into closed session.

The motion was seconded by Supervisor Davis.

AUTHORIZE AND APPROVE TO GO FROM CLOSED SESSION TO EXECUTIVE SESSION AS ALLOWED UNDER SECTION 25-41-7 OF THE MISSISSIPPI CODE TO DISCUSS A PERSONNEL MATTER

Supervisor Lummus moved to go from closed session to executive session as allowed under Section 25-41-7 of the Mississippi Code to discuss a personnel matter.

The motion was seconded by Supervisor Davis.

AUTHORIZE AND APPROVE TO COME OUT OF EXECUTIVE SESSION

Supervisor Lummus move to come out of Executive Session

The motion was seconded by Supervisor Horton.

RECESS

Supervisor Davis moved to recess until Thursday, July 8, 2021 at 9:00 a.m. at the Clay County Courthouse.

The motion was seconded by Supervisor Lummus.

***All motions were carried unanimously unless otherwise indicated.

SO ORDERED, this the 6th day of July, 2021.

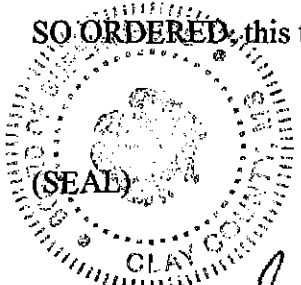

Shelton L. Deanes
SHELTON L. DEANES, PRESIDENT
CLAY COUNTY
BOARD OF SUPERVISORS

ATTEST:

Amy G. Berry
AMY G. BERRY, CHANCERY CLERK
CLERK OF THE BOARD

EXHIBIT A



*Clay County Board of Supervisors
Agenda for Meeting
Tuesday, July 6, 2021, at 9:00 a.m.*

- Call to Order
- Welcome and Prayer
- Adopt and Amend Agenda
- Authorize and approve the Claims Docket for the month of July 2021
- Authorize and approve for payment invoice as received from Randy Jones, Flood Plain Coordinator for services rendered
- Porsha Lee, *Clay County Tax Assessor/Collector*
 - Request 30-day extension with the MS Dept of Revenue for filing the Real and Personal Rolls with the County
- Authorize and approve Judge Chris McBrayer to travel to Biloxi, MS to Golden Nugget Saturday, July 17th thru Tuesday July 20th for MS Justice Court Judge's Association Summer Conference
- Consider the purchase request of County Attorney to purchase three (3) licenses for a drop box account
- Request to go into Executive Session to discuss a Personnel matter as allowed under Section 25-41-7 of *the Mississippi Code*
- Recess until Thursday, July 8, 2021 at 9:00 a.m. at the Clay County Courthouse

Amendments

EXHIBIT B

1

10:43:22

CLAIMS SUMMARY FOR: 7/2021

APCSCPR

FOR THE PERIOD ENDED JULY 05, 2021

CLAIM #	VENDOR NAME	AMOUNT
6454	DIXIE NET	210.00
6456	H. SCOTT ROSS	350.00
6457	JOSEPH HILLMAN, MD	200.00
6458	JOSEPH HILLMAN, MD	200.00
6459	REFRIGERATION SUPPLY COMPANY	2269.00
6460	WALMART COMMUNITY BRC	207.00
6461	AMY G. BERRY - FEES	156.00
6462	AMY G. BERRY - FEES	156.00
6466	MS STATE UNIV. EXTENSION SERV	1307.56
6467	AIRGAS SOUTH	214.94
6468	CASH & CARRY CLEANERS	15.00
6469	CASH & CARRY CLEANERS	20.00
6470	CASH & CARRY CLEANERS	30.00
6471	ADVANTAGE BUSINESS SYSTEMS	251.97
6472	LOWE'S HOME CENTER, INC.	444.49
6473	URGENT TEAM WEST POINT CENTER	140.00
6474	QUILL CORPORATION	41.98
6475	QUILL CORPORATION	78.94
6476	QUILL CORPORATION	299.90
6477	QUILL CORPORATION	192.29
6478	QUILL CORPORATION	419.95
6479	QUILL CORPORATION	269.99
6480	QUILL CORPORATION	19.99
6481	AMY G. BERRY - FEES	26.00
6482	QUILL CORPORATION	174.75
6483	QUILL CORPORATION	71.94
6484	QUILL CORPORATION	347.23
6485	AUTOZONE LLC	12.00
6486	SOUTHERN TELECOMMUNICATIONS	566.12
6487	SOUTHERN TELECOMMUNICATIONS	41.37
6489	FEDERAL EXPRESS CORP.	9.10
6490	EDMUND MILLER, JR, MD	500.00
6491	AUTOZONE LLC	24.00
6492	GEORGE'S TIRE SERVICE	80.00
6493	MID-SOUTH UNIFORMS	955.50
6494	DATASPEC INC.	449.00
6495	GALLS INCORPORATED	85.45
6496	GALLS INCORPORATED	157.99
6497	SUNFLOWER STORE	100.00
6498	WEST POINT SCHOOLS	69.93
6499	CITY OF WEST POINT	25.42
6500	DELUXE BUSINESS CHECKS	167.09
6502	WATCH GUARD VIDEO	13525.00
6503	WATCH GUARD VIDEO	250.00
6504	BEHAVIORAL MEDICINE	250.00
6505	CASH & CARRY CLEANERS	15.00
6506	CASH & CARRY CLEANERS	20.00

6507 CITY OF WEST POINT	697.24
6508 CITY OF WEST POINT	610.56
6509 WEST POINT SCHOOLS CLAY COUNTY	1679.04

PAGE

2
10:43:22 CLAIMS SUMMARY FOR: 7/2021
FOR THE PERIOD ENDED JULY 05, 2021
APCSCPR

CLAIM #	VENDOR NAME	AMOUNT
6510	WEST POINT SCHOOLS	1917.40
6511	KRISTEN WOOD WILLIAMS, PLLC	525.00
6512	SHRED IT	1190.02
6513	SHRED IT	688.28
6514	ORKIN- TUPELO, MS	110.00
6515	BELLSOUTH / ATT	36.86
6516	JT RAY COMPANY	230.40
6517	JT RAY COMPANY	94.82
6518	CLAY COUNTY CO-OP	26.50
6575	COMCAST CABLE	152.15
6581	CLAY COUNTY CO-OP	110.00
6582	CLAY COUNTY CO-OP	41.90
6583	PERFORMANCE AUTOMOTIVE, INC.	4185.72
6584	DELTA COMPUTER SYSTEMS, INC	80.00
6585	AUTOZONE LLC	68.17
6586	CLAY COUNTY CO-OP	20.95
6587	CASH & CARRY CLEANERS	20.00
6588	CASH & CARRY CLEANERS	15.00
6589	COOK'S CORRECTIONAL EQUIP.	1035.06
6590	LANN CHEMICAL	115.20
6591	LANN CHEMICAL	945.15
6592	LANN CHEMICAL	73.10
6593	LANN CHEMICAL	730.20
6595	CASH & CARRY CLEANERS	30.00
6599	PRECISION CAPTURE, INC.	9948.00
6600	LANN CHEMICAL	344.00
6601	M & M IMAGING LLC	692.48
6602	JIM'S AUTO PARTS, WEST POINT	136.99
6603	WALMART COMMUNITY BRC	13.38
6604	OFFICE SUPPLY HUT	60.98
6605	MS JUSTICE COURT JUDGES ASSOC.	250.00
6606	MS STATE MEDICAL EXAMINER	2000.00
6607	GOLDEN TRIANGLE PL & DEV DIST	224.00
6611	U. S. POSTMASTER	64.00
6612	DATA SYSTEMS MANAGEMENT, INC	3416.50
6613	GUEST BODY SHOP, LLC	60.00
6614	GUEST BODY SHOP, LLC	85.00
6615	GUEST BODY SHOP, LLC	85.00
6616	LANELL EARLY	80.00
6617	FUELMAN	1605.53
6618	OTIS ELEVATOR COMPANY	4116.60
6619	ALLEN, ALLEN, BREELAND & ALLEN	745.34
6620	URGENT TEAM WEST POINT CENTER	70.00
6621	CASH & CARRY CLEANERS	30.00

6622	ALCORN COUNTY, MS	3875.00
6624	R J YOUNG COMPANY	120.25
6625	SECURITY SOLUTIONS, LLC	276.00
6626	FUELMAN	1806.37
6627	CARQUEST AUTO PARTS, INC.	389.00
6628	VOICE WARE INC	169.00
6629	WALMART COMMUNITY BRC	246.98
6632	LANN CHEMICAL	68.80

CLAY COUNTY

PAGE

3

10:43:22

CLAIMS SUMMARY FOR: 7/2021
FOR THE PERIOD ENDED JULY 05, 2021

APCSCPR

CLAIM #	VENDOR NAME	AMOUNT
6633	DELTA COMPUTER SYSTEMS, INC	1049.00
6634	TOTAL LAWN CARE	100.00
6635	TOTAL LAWN CARE	120.00
6636	TOTAL LAWN CARE	80.00
6638	TOTAL LAWN CARE	395.00
6639	CITY WATER & LIGHT DEPT.	52.68
6640	CITY WATER & LIGHT DEPT.	226.10
6641	GOLDEN TRIANGLE WATER	32.50
6643	U. S. POSTMASTER	150.00
6644	BIGHAM TRUCKING	150.00
6645	S.E. CHICKASAW WATER ASSOC.	20.00
6646	AMY BERRY - EXPENSE ACCOUNT	248.64
6647	FUELMAN	1713.88
6648	SHELL FLEET PLUS	115.14
6650	FUELMAN	79.24
6651	QUILL CORPORATION	1439.99
6652	QUILL CORPORATION	65.45
6653	QUILL CORPORATION	17.98
6654	QUILL CORPORATION	167.29
6663	CADENCE BANK N. A.	45.00
6664	QUILL CORPORATION	69.98
6665	ALLMOND PRINTING	320.00
6666	MISSISSIPPI VITAL RECORDS	54.00
6670	MISSISSIPPI VITAL RECORDS	70.00
6671	MISSISSIPPI VITAL RECORDS	67.00
6673	ALLMOND PRINTING	359.00
6674	ITC DELTACOM, INC	1157.21
6677	ALLMOND PRINTING	88.00
6680	JAMES E. MCMILLIAN	150.00
6689	ALLMOND PRINTING	35.00
6692	ALLMOND PRINTING	165.00
6709	SUNFLOWER STORE	100.00
6710	SUNFLOWER STORE	100.00
6711	SUNFLOWER STORE	135.29
6713	LEON MOWRY	500.00
6714	REFRIGERATION SUPPLY COMPANY	310.22
6716	C SPIRE WIRELESS	34.29
6717	C SPIRE WIRELESS	103.16
6719	C SPIRE WIRELESS	43.31

6722 CLAY COUNTY CO-OP	555.00
6725 PHILLIP'S HARDWARE	1892.21
6726 AMY G. BERRY - FEES	26.00
6729 FERGUSON ENTERPRISES LLC #20	549.89
6730 TIM DOSS	28.56
6733 COMMUNITY COUNSELING	112.00
6734 ROSE DRUG COMPANY	749.00
6735 NATIONAL TEST SYSTEMS	75.00
6736 CASH & CARRY CLEANERS	30.00
6737 CASH & CARRY CLEANERS	15.00
6738 CASH & CARRY CLEANERS	20.00
6741 QUILL CORPORATION	119.97
6742 QUILL CORPORATION	34.99
10/19/2021 CLAY COUNTY	

PAGE

4

CLAIMS SUMMARY FOR: 7/2021
FOR THE PERIOD ENDED JULY 05, 2021

APCSCPR

CLAIM #	VENDOR NAME	AMOUNT
6743	QUILL CORPORATION	429.65
6744	A-1 CLEANING SERVICE	1500.00
6745	PREMIER RADIOLOGY	76.74
6746	CLAY COUNTY MEDICAL CENTER	2235.71
6750	SILAM WATER DISTRICT	25.00
6752	SILAM WATER DISTRICT	25.00
6754	COMCAST CABLE	224.03
6755	ORKIN- TUPELO, MS	57.50
6756	ORKIN- TUPELO, MS	45.00
6757	ORKIN- TUPELO, MS	91.00
6758	ORKIN- TUPELO, MS	84.00
6759	CITY WATER & LIGHT DEPT.	697.48
6762	FRANKLIN TELEPHONE COMPANY	2754.44
6764	GALLOWAY-CHANDLER-MCKINNEY	383.00
6765	MELISSA GRIMES	40.32
6767	EDMUND MILLER, JR, MD	500.00
6768	GUEST BODY SHOP, LLC	175.00
6769	JIM'S AUTO PARTS, WEST POINT	717.49
6770	MS INDUSTRIAL WASTE DISPOSAL	90.00
6771	MS INDUSTRIAL WASTE DISPOSAL	90.00
6772	MS INDUSTRIAL WASTE DISPOSAL	90.00
6775	RWJ CONSULTING, LLC	1144.40
6781	C SPIRE WIRELESS	704.88
6783	SCALES BIOLOGICAL LAB, INC	6167.50
6784	SAM'S CLUB	128.57
6785	JIM'S AUTO PARTS, WEST POINT	1245.12
6786	GEORGE'S TIRE SERVICE	2086.00
6787	GEORGE'S TIRE SERVICE	350.00
6788	GEORGE'S TIRE SERVICE	20.00
6789	SAM'S CLUB	259.70
6790	WOOD FRUITTICHER GROCERY CO	1294.92
6792	DRUG FREE WORKPLACES, INC	112.50
6793	DRUG FREE WORKPLACES, INC	138.00
6795	AMY G. BERRY - FEES	910.00

6796 SILOAM WATER DISTRICT	25.00
6797 AT & T	229.64
6810 CITY WATER & LIGHT DEPT.	1747.45
6811 CITY WATER & LIGHT DEPT.	270.97
6813 U S NETWORK	59.40
6814 ATMOS ENERGY	39.96
6815 ATMOS ENERGY	196.14
6816 ATMOS ENERGY	66.02
6818 LANN CHEMICAL	657.79
6819 QUILL CORPORATION	24.79
6820 QUILL CORPORATION	199.90
6821 QUILL CORPORATION	35.99
6823 FOUR-COUNTY ELEC POWER ASSN	232.00
6824 FOUR-COUNTY ELEC POWER ASSN	49.00
6825 FOUR-COUNTY ELEC POWER ASSN	50.00
6826 FOUR-COUNTY ELEC POWER ASSN	144.00
6828 FOUR-COUNTY ELEC POWER ASSN	148.00
6829 FOUR-COUNTY ELEC POWER ASSN	74.00

0/19/2021 CLAY COUNTY

PAGE

CLAIMS SUMMARY FOR: 7/2021
FOR THE PERIOD ENDED JULY 05, 2021

APCSCPR

CLAIM #	VENDOR NAME	AMOUNT
6830	FOUR-COUNTY ELEC POWER ASSN	70.00
6831	FOUR-COUNTY ELEC POWER ASSN	33.79
6832	FOUR-COUNTY ELEC POWER ASSN	84.00
6833	FOUR-COUNTY ELEC POWER ASSN	36.00
6834	FOUR-COUNTY ELEC POWER ASSN	46.00
6835	FOUR-COUNTY ELEC POWER ASSN	50.00
6836	FOUR-COUNTY ELEC POWER ASSN	70.00
6837	FOUR-COUNTY ELEC POWER ASSN	36.00
6838	FOUR-COUNTY ELEC POWER ASSN	48.00
6839	FOUR-COUNTY ELEC POWER ASSN	121.00
6865	WALMART COMMUNITY BRC	78.23
6869	COMMUNITY COUNSELING	375.00
6872	TEC	46.54
6874	LANN CHEMICAL	262.20
6879	CASH & CARRY CLEANERS	30.00
6880	COMCAST CABLE	189.64
6881	ALLIANCE HEALTH CENTER	900.00
6882	ALLIANCE HEALTH CENTER	75.00
6883	ALLIANCE HEALTH CENTER	75.00
6884	ALLIANCE HEALTH CENTER	6300.00
6886	COMCAST CABLE	149.64
6887	COMCAST CABLE	219.69
6888	FUELMAN	1790.33
6890	CASH & CARRY CLEANERS	15.00
6891	CASH & CARRY CLEANERS	20.00
6892	LEXIS NEXIS RISK DATA MNGTMENT	205.73
6893	MAGNOLIA BUSINESS SYSTEMS, INC	189.94
6894	MAGNOLIA BUSINESS SYSTEMS, INC	14.21
6895	MAGNOLIA BUSINESS SYSTEMS, INC	8.03

6896	MAGNOLIA BUSINESS SYSTEMS, INC	134.02
6897	MAGNOLIA BUSINESS SYSTEMS, INC	152.45
6898	MAGNOLIA BUSINESS SYSTEMS, INC	219.83
6899	MAGNOLIA BUSINESS SYSTEMS, INC	179.24
6900	MAGNOLIA BUSINESS SYSTEMS, INC	225.64
6901	MAGNOLIA BUSINESS SYSTEMS, INC	133.75
6902	MAGNOLIA BUSINESS SYSTEMS, INC	296.05
6903	MAGNOLIA BUSINESS SYSTEMS, INC	171.19
6904	MAGNOLIA BUSINESS SYSTEMS, INC	161.90
6905	WAUKAWAY DISTRIBUTORS INC.	24.60
6906	AMY G. BERRY - FEES	156.00
6907	AMY G. BERRY - FEES	156.00
6908	MARK CLIETT, ATTY.	350.00
6909	MARK CLIETT, ATTY.	350.00
6910	CLAY CO.DEPT./SOCIAL SERVICES	316.67
6911	DISTRICT ATTORNEY'S OFFICE	175.00
6912	GOLDEN TRIANGLE AREA	2583.33
6913	INSURANCE CLEARING ACCOUNT	1329.79
6914	HEALTH DEPT. OF CLAY COUNTY	3791.67
6915	COMMUNITY COUNSELLING SERVICE	2000.00
6916	NATIONAL GUARD OF MISSISSIPPI	200.00
6917	RESERVE ACCOUNT	2000.00
6918	CLAY COUNTY SWCD OFFICE	800.00

CLAY COUNTY

PAGE

6

10:43:22 CLAIMS SUMMARY FOR: 7/2021
FOR THE PERIOD ENDED JULY 05, 2021

APCSCPR

CLAIM #	VENDOR NAME	AMOUNT
6919	UNITED POSTAL SERVICE	625.00
6920	VICTIM WITNESS PROGRAM	1632.89
6921	VICTIM WITNESS PROGRAM	443.70
6966	LOCAL GOVERNMENT RECORDS OFFIC	240.50
6973	BANCORP SOUTH	4347.01
6984	LANN CHEMICAL	371.50
6991	CARDMEMBER SERVICE	1717.62
6992	CARDMEMBER SERVICE	4699.99
6993	CARDMEMBER SERVICE	27.00
6994	GOLDEN TRIANGLE DEVELOPMENT	87500.00
6995	MISSISSIPPI VITAL RECORDS	66.00
6996	MISSISSIPPI VITAL RECORDS	68.00
6997	CITY OF COLUMBUS	180.00
6998	MISSISSIPPI PUBLIC ENTITY	15684.25
6999	EDDIE SCOTT	420.89
7000	LYON INSURANCE AGENCY, INC	53221.00
7001	TANYA WEST	500.00
7002	CITY WATER & LIGHT DEPT.	7395.95
7003	CITY WATER & LIGHT DEPT.	2299.36
7004	CITY WATER & LIGHT DEPT.	1488.70
7007	DANIEL IRIONS	60.05
7009	NOTARY PUBLIC UNDERWRITERS	895.00
*** FUND TOTALS *** 001 GENERAL COUNTY		
326636.29		

7
 10:43:22 CLAY COUNTY PAGE
 CLAIMS SUMMARY FOR: 7/2021 APCSCPR
 FOR THE PERIOD ENDED JULY 05, 2021

CLAIM #	VENDOR NAME	AMOUNT
6608	SANDERS & ASSOCIATES	1000.00
6609	SANDERS & ASSOCIATES	3100.00
6610	SANDERS & ASSOCIATES	6000.00
*** FUND TOTALS *** 013 UTILIZATION		
10100.00		

8
 10:43:22 CLAY COUNTY PAGE
 CLAIMS SUMMARY FOR: 7/2021 APCSCPR
 FOR THE PERIOD ENDED JULY 05, 2021

CLAIM #	VENDOR NAME	AMOUNT
6642	COMCAST CABLE	99.00
6712	WALMART COMMUNITY BRC	486.26
6782	EDGAR ROWAN BULLOCK	750.00
6885	COMCAST CABLE	106.44
7005	SAM'S CLUB	1444.02
7006	SAM'S CLUB	97.61-
*** FUND TOTALS *** 040 SHERIFF'S INMATE CANTEEN		
2788.11		

9
 10:43:22 CLAY COUNTY PAGE
 CLAIMS SUMMARY FOR: 7/2021 APCSCPR
 FOR THE PERIOD ENDED JULY 05, 2021

CLAIM #	VENDOR NAME	AMOUNT
6970	TOMBIGBEE REGIONAL LIBRARY	1525.30
*** FUND TOTALS *** 095 SPECIAL LIBRARY LEVY		
1525.30		

10
 10:43:22 CLAY COUNTY PAGE
 CLAIMS SUMMARY FOR: 7/2021 APCSCPR
 FOR THE PERIOD ENDED JULY 05, 2021

CLAIM #	VENDOR NAME	AMOUNT
6488	SOUTHERN TELECOMMUNICATIONS	273.19
6753	BELLSOUTH / ATT	3466.00
6760	AT&T	107.00
6812	XEROX CORPORATION	57.24
6871	TEC	1.34
6974	HANCOCK BANK	2866.94
*** FUND TOTALS *** 097 E911 FUND		
5771.71		

11
 10:43:22 CLAY COUNTY PAGE
 CLAIMS SUMMARY FOR: 7/2021 APCSCPR
 FOR THE PERIOD ENDED JULY 05, 2021

CLAIM #	VENDOR NAME	AMOUNT
---------	-------------	--------

6637 TOTAL LAWN CARE 70.00
6718 C SPIRE WIRELESS 28.30
6766 LONNIE DAVIDSON 200.00
6972 MS DEVELOPMENT AUTHORITY 1386.57
*** FUND TOTALS *** 114 VOLUNTEER FIRE DEPARTMENT
1684.87

CLAY COUNTY

PAGE

12

10:43:22 CLAIMS SUMMARY FOR: 7/2021
FOR THE PERIOD ENDED JULY 05, 2021

APCSCPR

CLAIM # VENDOR NAME AMOUNT

6959 MS DEVELOPMENT AUTHORITY 2993.38
*** FUND TOTALS *** 116 INSURANCE REBATE MONIES
2993.38

CLAY COUNTY

PAGE

13

10:43:22 CLAIMS SUMMARY FOR: 7/2021
FOR THE PERIOD ENDED JULY 05, 2021

APCSCPR

CLAIM # VENDOR NAME AMOUNT

6875 MS DEVELOPMENT AUTHORITY 3300.93
6876 GOLDEN TRIANGLE DEVELOPMENT 133.34
6877 GOLDEN TRIANGLE DEVELOPMENT 350.00
*** FUND TOTALS *** 138 TVA BRIDGE BOND MONEY
3784.27

CLAY COUNTY

PAGE

14

10:43:22 CLAIMS SUMMARY FOR: 7/2021
FOR THE PERIOD ENDED JULY 05, 2021

APCSCPR

CLAIM # VENDOR NAME AMOUNT

6519 PHILLIP'S HARDWARE 208.83
6522 ARAMARK UNIFORM SERVICES INC 58.99
6563 ARAMARK UNIFORM SERVICES INC 58.99
6679 CARQUEST AUTO PARTS, INC. 43.00
6681 CARQUEST AUTO PARTS, INC. 2.48
6682 CARQUEST AUTO PARTS, INC. 54.99
6686 45 TRUCK AND TRAILER REPAIR 24.34
6688 H & R AGRI-POWER 21.16
6690 CLAY COUNTY CO-OP 15.25
6691 CLAY COUNTY CO-OP 890.00
6693 CITY WATER & LIGHT DEPT. 40.24
6695 ARAMARK UNIFORM SERVICES INC 58.99
6801 PHILLIP'S HARDWARE 20.98
6866 BEARINGS & SUPPLY OF TUEPLO 75.40
6867 O'REILLY AUTO PARTS 23.97
6868 CARQUEST AUTO PARTS, INC. 199.85
6923 TRACTOR SUPPLY CREDIT PLAN 131.98
6925 FOUR-COUNTY ELEC POWER ASSN 36.60
6926 FOUR-COUNTY ELEC POWER ASSN 124.00
*** FUND TOTALS *** 151 DISTRICT 1 ROAD

2090.04

CLAY COUNTY

PAGE

15

10:43:22

CLAIMS SUMMARY FOR: 7/2021
FOR THE PERIOD ENDED JULY 05, 2021

APCSCPR

CLAIM #	VENDOR NAME	AMOUNT
6576	GUEST BODY SHOP, LLC	8662.51
6578	JIM'S AUTO PARTS, WEST POINT	19.99
6579	JIM'S AUTO PARTS, WEST POINT	55.98
6732	WHITE OIL CO., INC.& TIRE CTR.	2915.27
*** FUND TOTALS *** 152 DISTRICT 2 ROAD		
		11653.75

CLAY COUNTY

PAGE

16

10:43:22

CLAIMS SUMMARY FOR: 7/2021
FOR THE PERIOD ENDED JULY 05, 2021

APCSCPR

CLAIM #	VENDOR NAME	AMOUNT
6535	PHILLIP'S HARDWARE	13.98
6536	TIPTON'S TRUCK REPAIR LLC	153.97
6539	CARQUEST AUTO PARTS, INC.	121.04
6540	RACKLEY OIL COMPANY, INC	340.45
6702	GEORGE'S TIRE SERVICE	178.00
6703	TERRY'S GARAGE AND REPAIR	195.66
6704	CARQUEST AUTO PARTS, INC.	20.98
6705	CARQUEST AUTO PARTS, INC.	126.49
6706	CLAY COUNTY CO-OP	5.00
6707	MIKE'S QWIK STOP	26.99
6715	C SPIRE WIRELESS	47.31
6720	INGRAMS GARAGE	514.50
6747	CARQUEST AUTO PARTS, INC.	41.85
6748	CARQUEST AUTO PARTS, INC.	61.80
6749	CARQUEST AUTO PARTS, INC.	563.00
6761	MIKE LOYD	143.00
6776	SILAM WATER DISTRICT	25.00
6777	GRAY'S TIRE SERVICE	520.90
6778	GRAY'S TIRE SERVICE	520.90
6988	FOUR-COUNTY ELEC POWER ASSN	36.60
6989	FOUR-COUNTY ELEC POWER ASSN	76.00
*** FUND TOTALS *** 153 DISTRICT 3 ROAD		
		3733.42

CLAY COUNTY

PAGE

17

10:43:22

CLAIMS SUMMARY FOR: 7/2021
FOR THE PERIOD ENDED JULY 05, 2021

APCSCPR

CLAIM #	VENDOR NAME	AMOUNT
6568	ARAMARK UNIFORM SERVICES INC	28.16
6954	FOUR-COUNTY ELEC POWER ASSN	36.60
*** FUND TOTALS *** 154 DISTRICT 4 ROAD		
		64.76

CLAY COUNTY

PAGE

CLAIM #	VENDOR NAME	AMOUNT
6549	BACCO MATERIALS, INC.	584.55
6550	BACCO MATERIALS, INC.	2980.79
6552	GOLDEN TRIANGLE TIRE SVC LLC	182.99
6553	CHICKASAW EQUIPMENT CO.	48.04
6554	WADE, INC.	443.00
6555	JIM'S AUTO PARTS, WEST POINT	6.29
6556	PRESTON DOBBS TRUCKING AND	840.00
6558	THOMPSON MACHINERY	3889.94
6574	CLAY COUNTY CO-OP	445.00
6598	SUN CREEK WATER ASSN.	17.00
6708	45 TRUCK AND TRAILER REPAIR	24.33
6809	TERRY'S GARAGE AND REPAIR	548.13
6957	HANCOCK BANK	1158.99
6975	C SPIRE WIRELESS	40.70
6977	FOUR-COUNTY ELEC POWER ASSN	205.00
6978	FOUR-COUNTY ELEC POWER ASSN	36.60
6979	JIM'S AUTO PARTS, WEST POINT	55.20
6980	JIM'S AUTO PARTS, WEST POINT	67.73
6981	BACCO MATERIALS, INC.	251.94
6982	COLD MIX, INC.	2033.04
6983	WARREN PAVING	649.50

*** FUND TOTALS *** 155 DISTRICT 5 ROAD
14508.76

CLAY COUNTY

PAGE

CLAIM #	VENDOR NAME	AMOUNT
6520	LOWE'S HOME CENTER, INC.	332.50
6521	BACCO MATERIALS, INC.	1717.58
6523	SOUTHERN TELECOMMUNICATIONS	42.83
6524	WHITE OIL CO., INC.& TIRE CTR.	2723.50
6525	PRESTON DOBBS TRUCKING AND	176.00
6526	PRESTON DOBBS TRUCKING AND	231.00
6561	FUELMAN	255.55
6562	FUELMAN	175.73
6597	H & O TRUCK & TRAILER REPAIR	29.49
6667	KELLOGG HARDWARE & APPLIANCE	30.99
6668	KELLOGG HARDWARE & APPLIANCE	5.24
6669	KELLOGG HARDWARE & APPLIANCE	50.48
6672	KELLOGG HARDWARE & APPLIANCE	3.84
6675	CARQUEST AUTO PARTS, INC.	41.64
6676	CARQUEST AUTO PARTS, INC.	33.49
6678	CARQUEST AUTO PARTS, INC.	4.96
6683	CARQUEST AUTO PARTS, INC.	39.09
6684	CARQUEST AUTO PARTS, INC.	29.69
6685	CARQUEST AUTO PARTS, INC.	49.47

6687 PHILLIP'S HARDWARE	195.98
6694 FUELMAN	275.24
6696 JIM'S AUTO PARTS, WEST POINT	62.46
6697 JIM'S AUTO PARTS, WEST POINT	40.48
6802 C SPIRE WIRELESS	60.26
6803 CLAY COUNTY CO-OP	71.55
6822 COLD MIX, INC.	1979.72
6922 FUELMAN	243.46
6924 WARREN PAVING	120.06
6927 WARREN PAVING	248.68
6928 WARREN PAVING	256.27
6929 BACCO MATERIALS, INC.	1723.42
6930 SUNFLOWER STORE	13.77
6931 SUNFLOWER STORE	17.90
6932 SUNFLOWER STORE	9.18
6933 SUNFLOWER STORE	10.18
6934 SUNFLOWER STORE	13.77
6935 SUNFLOWER STORE	12.84
6936 SUNFLOWER STORE	9.18
6937 SUNFLOWER STORE	13.77
6938 SUNFLOWER STORE	13.77
6939 SUNFLOWER STORE	9.18
6940 SUNFLOWER STORE	11.03
6941 SUNFLOWER STORE	9.18
6942 SUNFLOWER STORE	9.18
6943 SUNFLOWER STORE	9.18
6944 SUNFLOWER STORE	9.18
6945 SUNFLOWER STORE	9.18
6946 SUNFLOWER STORE	9.18
6947 SUNFLOWER STORE	9.18
6948 SUNFLOWER STORE	4.59
6949 SUNFLOWER STORE	4.59
6950 SUNFLOWER STORE	9.18

CLAY COUNTY

PAGE

20

10:43:22 CLAIMS SUMMARY FOR: 7/2021
FOR THE PERIOD ENDED JULY 05, 2021

APCSCPR

CLAIM #	VENDOR NAME	AMOUNT
6955	HANCOCK BANK	1158.98
*** FUND TOTALS *** 161 DISTRICT 1 BRIDGE		
		12626.82

CLAY COUNTY

PAGE

21

10:43:22 CLAIMS SUMMARY FOR: 7/2021
FOR THE PERIOD ENDED JULY 05, 2021

APCSCPR

CLAIM #	VENDOR NAME	AMOUNT
6527	WILLIAMS EQUIPMENT & SUPPLY	832.82
6528	BACCO MATERIALS, INC.	722.49
6529	GOLDEN TRIANGLE TIRE SVC LLC	18.00
6530	GOLDEN TRIANGLE TIRE SVC LLC	171.00
6531	PHILLIP'S HARDWARE	47.76

6532 PRESTON DOBBS TRUCKING AND	385.00
6560 MMC MATERIALS INC	412.50
6564 PHILLIP'S HARDWARE	5.98
6569 PHILLIP'S HARDWARE	5.69
6570 WARREN PAVING	446.53
6571 WARREN PAVING	242.01
6572 WARREN PAVING	532.29
6577 PHILLIP'S HARDWARE	6.74
6580 CLAY COUNTY CO-OP	445.00
6698 CARQUEST AUTO PARTS, INC.	25.00
6699 CITY WATER & LIGHT DEPT.	35.00
6700 GOLDEN TRIANGLE WATER	32.50
6701 WILLIAMS EQUIPMENT & SUPPLY	684.90
6721 CLAY COUNTY CO-OP	195.00
6724 JIM'S AUTO PARTS, WEST POINT	318.90
6731 ARTHUR MATHEWS	3800.00
6739 PHILLIP'S HARDWARE	533.20
6804 COLUMBUS WHOLESALE TIRE	569.70
6805 C SPIRE WIRELESS	28.08
6806 GEORGE'S TIRE SERVICE	20.40
6807 ORMAN'S WELDING & FAB., INC.	222.00
6808 MS INDUSTRIAL WASTE DISPOSAL	106.40
6840 TIPTON'S TRUCK REPAIR LLC	127.50
6841 TIPTON'S TRUCK REPAIR LLC	633.00
6842 TIPTON'S TRUCK REPAIR LLC	358.98
6985 BRAD'S ON SITE SERVICE, LLC	404.80
6986 FOUR-COUNTY ELEC POWER ASSN	36.60
6987 FOUR-COUNTY ELEC POWER ASSN	301.00
*** FUND TOTALS *** 162 DISTRICT 2 BRIDGE	
12706.77	

CLAY COUNTY

PAGE

22

10:43:22

CLAIMS SUMMARY FOR: 7/2021
FOR THE PERIOD ENDED JULY 05, 2021

APCSCPR

CLAIM #	VENDOR NAME	AMOUNT
6541	WHITE OIL CO., INC.& TIRE CTR.	2438.90
***	FUND TOTALS *** 163 DISTRICT 3 BRIDGE	
	2438.90	

CLAY COUNTY

PAGE

23

10:43:22

CLAIMS SUMMARY FOR: 7/2021
FOR THE PERIOD ENDED JULY 05, 2021

APCSCPR

CLAIM #	VENDOR NAME	AMOUNT
6542	ARAMARK UNIFORM SERVICES INC	28.16
6543	GOLDEN TRIANGLE TIRE SVC LLC	90.00
6544	GOLDEN TRIANGLE TIRE SVC LLC	20.00
6545	O'REILLY AUTO PARTS	370.52
6546	ARAMARK UNIFORM SERVICES INC	28.16
6547	PRESTON DOBBS TRUCKING AND	308.00
6548	G & O SUPPLY CO, INC	11163.40
6565	COLD MIX, INC.	2024.44

6566 AMERIMAC CHEMICAL	228.00
6567 BACCO MATERIALS, INC.	1222.07
6727 45 TRUCK AND TRAILER REPAIR	24.33
6728 WESDAK INC.	294.64
6773 SILOAM WATER DISTRICT	25.00
6774 C SPIRE WIRELESS	57.26
6779 ARAMARK UNIFORM SERVICES INC	28.16
6951 FOUR-COUNTY ELEC POWER ASSN	149.00
6952 FOUR-COUNTY ELEC POWER ASSN	41.00
6953 FOUR-COUNTY ELEC POWER ASSN	79.87
6956 HANCOCK BANK	1158.99

*** FUND TOTALS *** 164 DISTRICT 4 BRIDGE
17341.00

CLAY COUNTY

PAGE

24

10:43:22 CLAIMS SUMMARY FOR: 7/2021
FOR THE PERIOD ENDED JULY 05, 2021

APCSCPR

CLAIM #	VENDOR NAME	AMOUNT
---------	-------------	--------

6551 WHITE OIL CO., INC.& TIRE CTR.	553.30
6557 WADE, INC.	1705.31
6559 THOMPSON MACHINERY	2435.23
6958 HANCOCK BANK	1867.01
6976 RACKLEY OIL COMPANY, INC	4275.16

*** FUND TOTALS *** 165 DISTRICT 5 BRIDGE
10836.01

CLAY COUNTY

PAGE

25

10:43:22 CLAIMS SUMMARY FOR: 7/2021
FOR THE PERIOD ENDED JULY 05, 2021

APCSCPR

CLAIM #	VENDOR NAME	AMOUNT
---------	-------------	--------

6533 BACCO MATERIALS, INC.	242.78
6534 BACCO MATERIALS, INC.	719.36
6537 BACCO MATERIALS, INC.	981.74
6538 PRESTON DOBBS TRUCKING AND	231.00
6990 BACCO MATERIALS, INC.	742.86

*** FUND TOTALS *** 173 D-3 ROAD CONSTRUCTION - USE TAX
2917.74

CLAY COUNTY

PAGE

26

10:43:22 CLAIMS SUMMARY FOR: 7/2021
FOR THE PERIOD ENDED JULY 05, 2021

APCSCPR

CLAIM #	VENDOR NAME	AMOUNT
---------	-------------	--------

6573 G & O SUPPLY CO, INC	5529.90
---------------------------	---------

*** FUND TOTALS *** 175 D-5 ROAD CONSTRUCTION - USE TAX
5529.90

CLAY COUNTY

PAGE

27

10:43:22 CLAIMS SUMMARY FOR: 7/2021
FOR THE PERIOD ENDED JULY 05, 2021

APCSCPR

CLAIM #	VENDOR NAME	AMOUNT
---------	-------------	--------

6763 BUTLER SNOW ATTORNEYS 8500.00
*** FUND TOTALS *** 322 D-2 ROAD B & I 2021 CONSTRUCTION
8500.00

CLAY COUNTY

PAGE

28

10:43:22

CLAIMS SUMMARY FOR: 7/2021
FOR THE PERIOD ENDED JULY 05, 2021

APCSCPR

CLAIM #	VENDOR NAME	AMOUNT
6455	PHILLIP'S HARDWARE	12.05
6463	PHILLIP'S HARDWARE	9.27
6464	PHILLIP'S HARDWARE	8.18
6465	PHILLIP'S HARDWARE	44.08
6501	JIM'S AUTO PARTS, WEST POINT	86.13
6594	PHILLIP'S HARDWARE	27.32
6596	FUELMAN	762.36
6623	FUELMAN	772.79
6630	JIM'S AUTO PARTS, WEST POINT	42.99
6631	PHILLIP'S HARDWARE	25.99
6649	FUELMAN	515.51
6655	JIM'S AUTO PARTS, WEST POINT	54.97
6656	JIM'S AUTO PARTS, WEST POINT	19.98
6657	JIM'S AUTO PARTS, WEST POINT	18.49
6658	JIM'S AUTO PARTS, WEST POINT	122.99
6659	JIM'S AUTO PARTS, WEST POINT	9.99
6660	JIM'S AUTO PARTS, WEST POINT	35.05
6661	JIM'S AUTO PARTS, WEST POINT	21.98
6662	JIM'S AUTO PARTS, WEST POINT	26.96
6723	CLAY COUNTY CO-OP	43.89
6740	HANCOCK EQUIPMENT & OIL CO.	84.00
6751	SILOAM WATER DISTRICT	25.00
6780	HEATH DONAHOO	265.00
6791	PHILLIP'S HARDWARE	16.66
6794	PHILLIP'S HARDWARE	14.16
6798	TIPTON'S TRUCK REPAIR LLC	340.00
6799	TIPTON'S TRUCK REPAIR LLC	56.00
6800	TIPTON'S TRUCK REPAIR LLC	50.00
6817	GTR SOLID WASTE MGMT AUTHORITY	5067.41
6827	FOUR-COUNTY ELEC POWER ASSN	57.00
6843	SUNFLOWER STORE	13.77
6844	SUNFLOWER STORE	9.18
6845	SUNFLOWER STORE	13.77
6846	SUNFLOWER STORE	15.66
6847	SUNFLOWER STORE	16.74
6848	SUNFLOWER STORE	15.76
6849	SUNFLOWER STORE	9.18
6850	SUNFLOWER STORE	12.06
6851	SUNFLOWER STORE	13.77
6852	SUNFLOWER STORE	13.77
6853	SUNFLOWER STORE	13.77
6854	SUNFLOWER STORE	9.18
6855	SUNFLOWER STORE	9.18

6856 SUNFLOWER STORE	13.77
6857 SUNFLOWER STORE	9.18
6858 SUNFLOWER STORE	9.18
6859 SUNFLOWER STORE	9.18
6860 SUNFLOWER STORE	9.18
6861 SUNFLOWER STORE	19.74
6862 SUNFLOWER STORE	4.59
6863 SUNFLOWER STORE	4.59
6864 SUNFLOWER STORE	19.26

CLAY COUNTY

PAGE

29

0:43:22 CLAIMS SUMMARY FOR: 7/2021
FOR THE PERIOD ENDED JULY 05, 2021

APCSCPR

CLAIM # VENDOR NAME AMOUNT

6870 PHILLIP'S HARDWARE	99.85
6873 PHILLIP'S HARDWARE	40.07
6878 TIPTON'S TRUCK REPAIR LLC	856.00
6889 FUELMAN	853.31
7008 GOLDEN TRIANGLE PL & DEV DIST	2945.19

*** FUND TOTALS *** 400 SANITATION

13695.08

CLAY COUNTY

PAGE

30

0:43:22 CLAIMS SUMMARY FOR: 7/2021
FOR THE PERIOD ENDED JULY 05, 2021

APCSCPR

CLAIM # VENDOR NAME AMOUNT

6960 STATE TREASURER	27598.50
6961 MS DEPT OF PUBLIC SAFETY	940.00
6962 MS DEPT OF PUBLIC SAFETY	160.50
6963 MS DEPT OF PUBLIC SAFETY	500.00
6964 GOLDEN TRIANGLE CRIME STOPPERS	189.50

*** FUND TOTALS *** 650 JUDICIAL ASSESSMENT CLEARING FUND

29388.50

CLAY COUNTY

PAGE

31

0:43:22 CLAIMS SUMMARY FOR: 7/2021
FOR THE PERIOD ENDED JULY 05, 2021

APCSCPR

CLAIM # VENDOR NAME AMOUNT

6971 EAST MS COMMUNITY COLLEGE	3772.38
--------------------------------	---------

*** FUND TOTALS *** 690 EMJC MAINTENANCE

3772.38

CLAY COUNTY

PAGE

32

0:43:22 CLAIMS SUMMARY FOR: 7/2021
FOR THE PERIOD ENDED JULY 05, 2021

APCSCPR

CLAIM # VENDOR NAME AMOUNT

6967 EAST MISS. COMMUNITY COLLEGE	2403.86
-----------------------------------	---------

*** FUND TOTALS *** 692 EMCC CAPITAL IMPROVEMENT CAMPAIGN

2403.86

CLAY COUNTY

PAGE

33

10:43:22

CLAIMS SUMMARY FOR: 7/2021
FOR THE PERIOD ENDED JULY 05, 2021

APCSCPR

CLAIM # VENDOR NAME AMOUNT

6968 EAST MISS. COMMUNITY COLLEGE 2060.30
*** FUND TOTALS *** 697 VO-TECH MAINTENANCE
2060.30

CLAY COUNTY

PAGE

34

10:43:22

CLAIMS SUMMARY FOR: 7/2021
FOR THE PERIOD ENDED JULY 05, 2021

APCSCPR

CLAIM # VENDOR NAME AMOUNT

6969 EAST MISS. COMMUNITY COLLEGE 1819.14
*** FUND TOTALS *** 698 VO-TECH CAPITAL
1819.14

CLAY COUNTY

PAGE

35

10:43:22

CLAIMS SUMMARY FOR: 7/2021
FOR THE PERIOD ENDED JULY 05, 2021

APCSCPR

CLAIM # VENDOR NAME AMOUNT

6965 TOMBIGBEE RIVER WTR, MGMT DIST 2380.88
*** FUND TOTALS *** 699 TOMBIGBEE RIVER VALLEY WATER MGMT.DIST.
2380.88
*** DOCKET TOTALS ***
516751.94

I CERTIFY THAT THE BOARD HAS EXAMINED EACH CLAIM ON THE JULY, 2021
DOCKET AND THE BILLS THEY REPRESENT AND FINDS EACH OF THE ABOVE DUE AND
PAYABLE AND DIRECT THE CLERK TO ISSUE WARRANTS ON THE RESPECTIVE FUNDS.
THIS THE 05TH DAY OF JULY 2021



Shelton L. Deames

PRESIDENT

EXHIBIT C

7

7

7



Clay County Floodplain Administrator

Clay County Administrator

P.O. Box 815
West Point, Mississippi 39773
Phone (662) 494-3124
Fax (662) 492-4059
E-mail: supervisors@claycounty.ms.gov

Randolph "Randy" Jones, CFM

July 6, 2021

County Board of Supervisors
The Honorable Shelton Deanes, President
P.O. Box 815
West Point, MS 39773

Dear Mr. Deanes,

Enclosed you will find my current summary of actions June 7th, 2021 through July 6th, 2021 and incurred expense as Clay County Floodplain Administrator for consulting, travel, continuing education attendance, and inspections for the Board of Supervisors' review. I am attaching a detailed invoice for my actions and expenses as well as file copies of correspondence.

Thank you so much for your interest and diligence in attending to issues that protect citizens and property, as well as, saving the tax payers' money.

We continue to make considerable progress collating materials and actions to pursue participation in the Community Rating System (CRS); however, after much study, I do not harbor as much support to proceed as previously believed. The program has taken on a much more bureaucratic overtone common to many programs with federal governance.

Sincerely,

Randolph W. Jones, CFM
Clay County Floodplain Administrator

Encl as
cf. Clay County Chancery Clerk

RWJ Consulting, LLC

Invoice for: Clay County Floodplain Administration June 7, 2021 – July 6, 2021

Clay County Board of Supervisors
Attn: The Honorable Shelton Deanes, President
P.O. Box 815, West Point, MS 39773

ITEM	¹ HOURS	*MILEAGE	TOTAL
06/10/21 Conference, letter, Jamond Nance, 809 Humphries Cove Road West Point, MS 39773	0.5 @ \$24.00=\$12.00 0.5 @ \$48.00=\$24.00	See Attachment	\$36.00
06/14/21 Research, travel, letter, Jamond Nance, 809 Humphries Cove Road West Point, MS 39773	1.0 @ \$24.00=\$24.00 0.5 @ \$48.00=\$24.00	See Attachment	\$48.00
06/14/21 Conference, research, travel, letter Thomas Smith, 909 Clisby Road, West Point, MS 39773	1.0 @ \$24.00=\$24.00 0.5 @ \$48.00=\$24.00	See Attachment	\$48.00
06/14/21 Conference, research, travel letter Michael Rogers, Jr., CCC Line Road, Prairie, MS 30756	1.0 @ \$24.00=\$24.00 1.0 @ \$48.00=\$48.00	See Attachment	\$72.00
06/15/21 Conference, research, travel, letter Veniece Logan or Kendrick Coleman, 29546 Highway 50 East, West Point, MS 39773	1.0 @ \$24.00=\$24.00 0.5 @ \$48.00=\$24.00	See Attachment	\$48.00
06/17/21 Conference, research, travel, letter Henry & Ozzie Weatherspoon, 258 Hopewell Road, Cedar Bluff, MS 39741	1.0 @ \$24.00=\$24.00 0.5 @ \$48.00=\$24.00	See Attachment	\$48.00
06/22/21 Conference, research, travel, letter Matthew Lewis (George Davidson) 98 Garth Road, Prairie, MS 39756	1.0 @ \$24.00=\$24.00 1.0 @ \$48.00=\$48.00	See Attachment	\$72.00
07/01/21 Conference, research, travel, letter William Guy (Mamie Gibbs Estate) Waverly Road, West Point, MS 39773	1.0 @ \$24.00=\$24.00 1.0 @ \$48.00=\$48.00	See Attachment	\$72.00
07/03/21 Conference, research, travel, letter Doris Brown (Katie Walker) 1806 Melton Bottom Road, West Point, MS 39773	1.0 @ \$24.00=\$24.00 1.5 @ \$48.00=\$72.00	See Attachment	\$96.00
07/03/21 Conference, research, travel, letter James Otis Holliday, 1844 Brand-Una Road, Prairie, MS 39756	1.5 @ \$24.00=\$36.00 1.0 @ \$48.00=\$48.00	See Attachment	\$84.00
07/03/21 Conference, research, travel, letter Georgenna Edwards (Homer Ivy) 821 Pinkerton Road, West Point, MS 39773	1.0 @ \$24.00=\$24.00 1.0 @ \$48.00=\$48.00	See Attachment	\$72.00
07/03/21 Conference, letter Jamond Nance, 809 Humphries Cove Road, West Point, MS 39773	0.5 @ \$24.00=\$12.00 0.5 @ \$48.00=\$24.00	See Attachment	\$36.00
06/04/21 – 07/06/21 Travel Driving time, report and copies for Board of Supervisors, Tax Assessor, Property Owners, & MEMA	6.5 @ \$24.00=\$156.00 3.0 @ \$48.00=\$144.00	234.2 @ \$0.48=\$112.40 See Attachment	\$412.40
TOTALS	\$1,032.00	\$112.40	\$1,144.40

¹ Driving time billed at half technical/research rate. Copies of correspondence, research, and letters are attached.

Respectfully Submitted:



Please mail to: **RWJ Consulting, LLC**
P.O. Box 0694
West Point, Mississippi 39773

RWJ/rj
Encl as

EXHIBIT D

[

[

[

Amy G Berry

From: plee@claycounty.ms.gov
Sent: Wednesday, June 24, 2020 5:08 PM
To: 'Amy Berry'
Subject: RE: Meeting Tomorrow

30 day extension for the tax roll

Porsha J Lee, Tax Assessor/Collector
Clay County, MS
PO Box 795
365 Court Street
West Point, MS 39773
(662) 494-3432
(662) 494-7452 fax
plee@claycounty.ms.gov

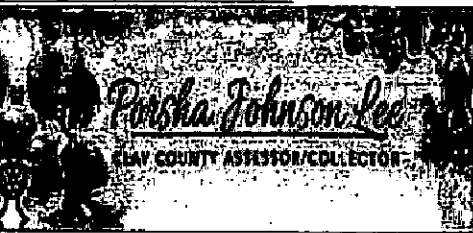

Due to medical / health
Delays by the contractor
Sendles + Associates

From: Amy Berry <aberry@claycounty.ms.gov>
Sent: Wednesday, June 24, 2020 10:26 AM
To: plee@claycounty.ms.gov; Treva Hodge <thodge@claycounty.ms.gov>
Subject: Meeting Tomorrow

Do either of you ladies have anything for the agenda tomorrow?

Amy Berry
Chancery Clerk
Clay County, MS
P O Box 815
West Point, MS 39773
(662) 494-3124
(662) 492-4059 FAX
aberry@claycounty.ms.gov

EXHIBIT E

[]

[]

[]

IN THE MATTER OF AUTHORIZING AND APPROVING
TO GRANT AN INDUSTRIAL TAX EXEMPTION ON
PERSONAL PROPERTY FOR FABRICATOR'S SUPPLY, INC.

There came on this day for consideration the matter of authorizing and approving to grant an Industrial Tax Exemption on Personal Property for Fabricator's Supply, Inc.

It appears to this Board that Fabricator's Supply Inc. is requesting this Board grant an industrial tax exemption on personal property as outlined in their application as attached hereto in Exhibit A with a total value of \$750,000 for a period of ten (10) years beginning January 1, 2021 and ending December 31, 2031.

Supervisor Horton moved to authorize and approve to grant the Industrial Tax Exemption on the personal property for ten (10) years with a total value of \$750,000 according to the authority of Section 27-31-101, *et seq.*, of the *Mississippi Code of 1972*, as amended and annotated.

The motion was seconded by Supervisor Chandler.

The motion carried unanimously.

SO ORDERED, this the 6th day of July, 2021.

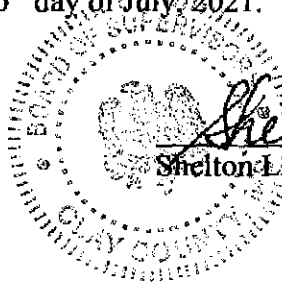

Shelton L. Deanes, President

ATTEST:

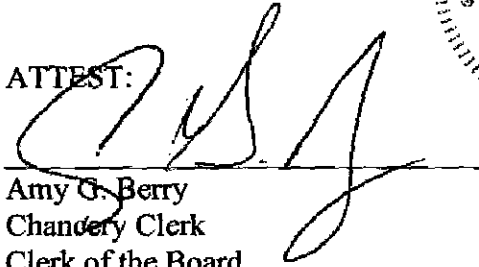
Amy G. Berry
Chancery Clerk
Clerk of the Board



**Fabricators
Supply**

205 Airport Road
West Point, MS 39773
Phone: 866-492-0550 Fax: 662-492-0380

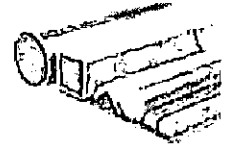

January 1/25/21

Application of Fabricators Supply, LLC for Exemption

To Clay County Board of Supervisors:

Fabricators Supply is a Steel Processing and Steel Warehouse located at 205 Airport Rd West Point, MS. Over the last few years we continue to invest in West Point, with the most cutting edge equipment in the market. We have expanded our footprint to cover the Southeastern portion of the US. With this equipment we have created 4-5 new jobs immediately.

Fabricators Supply is submitting the attached application for exemption from ad valorem taxation

Sincerely,
Dave Ketchum
GM
Fabricators Supply
205 Airport Rd
West Point, MS

Web Site: www.fab-supply.com

APPLICATION FOR AD VALOREM TAX EXEMPTION

AS AUTHORIZED BY SECTION 27-31-101, et seq., MISSISSIPPI CODE OF 1972, AS AMENDED

NAME OF ENTERPRISE Fabricators Supply
PHYSICAL ADDRESS 205 Air Port Rd
TYPE OF INDUSTRY Steel PRODUCT/SERVICE Distribution / Processing
LOCATION - COUNTY Clay CITY West Point
DATE OF COMPLETION 11/17/20 YEARS REQUESTED 10
NEW (SECTION 27-31-101) _____ EXPANSION (SECTION 27-31-105) X
NEW JOBS 4 ESTIMATED PAYROLL \$200,000
TRUE VALUE OF PROPERTY EXEMPTED \$750,000 *Attach an
itemized list of property to be exempted as Exhibit "A".

The applicant request that the Board approve this application by an order spread on its minutes declaring that the above property be exempt from all ad valorem taxation except school taxation for the period requested. The applicant further request that the application and certified approval of exemption be forwarded to the Department of Revenue and upon approval and certification by the Department, the Board enter a final order on its minutes granting the exemption. The above information is true and correct as certified by the applicant. This application is submitted on the 25th day of January, 2021

Fabricators Supply
Applicant (Name of Taxpayer)

By: [Signature]
Title: GM

ATTEST



**Fabricators
Supply**

205 Airport Road
West Point, MS 39773
Phone: 866-492-0550 Fax: 662-492-0380



Exhibit A

Year: 2020

Description: Voortman V807 Robotic Plasma and material handling system.

Cost: \$750,000

Web Site: www.fab-supply.com

EXHIBIT F



Golden Nugget Invoice

Invoice to be paid in full to Golden Nugget by Thursday, June 17, 2021.

COUNTY Clay

JUDGE'S NAME Chris McBayer

FROM: Golden Nugget Biloxi

DATE SUBMITTED _____

RE: **2021 MJCJA Summer Convention:
Pre-Payment of Hotel Rate & Resort Fee**

Please submit this completed invoice to your county for payment. *The county tax exempt letter, and a copy of this invoice, must accompany the check when mailed to the Golden Nugget Biloxi.*

Mark the nights you will be making reservations, total, and submit to your county for pre-payment of hotel room rate and resort fee:

- Saturday, July 17th (\$222.98) (For MJCJA Board Members Only)
- Sunday, July 18th (\$132.98)
- Monday, July 19th (\$132.98)
- Tuesday, July 20th (\$132.98)
- Wednesday, July 21st (\$132.98)

Total Due Golden Nugget by Thursday, June 17th \$ 0.00

Please make checks payable to:
Golden Nugget Biloxi and include 2021 MJCJA and judge's name on the memo line.

Remit to:
*Golden Nugget Accounting
151 Beach Boulevard
Biloxi, MS 39530*

The above fee must be submitted to the Golden Nugget Biloxi by: *Thursday, June 17, 2021.*

Please attach a copy of the county tax exempt letter, and this invoice, to the check when mailed.



MJCJA INVOICE

Invoice to be paid in full to MJCJA by Wednesday, June 30, 2021.

COUNTY Clay

JUDGE'S NAME Chris McBrayer

FROM: Mississippi Justice Court Judges Association

DATE SUBMITTED _____

RE: **Registration Fee Invoice**
Mississippi Justice Court Judges Assn. Summer Convention
Golden Nugget Biloxi - July 18-22, 2021

Please submit this completed invoice to your county for payment:

<input checked="" type="checkbox"/>	MJCJA Convention Registration Fee <i>(Amount Required to Attend)</i>	\$ 500.00
-------------------------------------	---	-----------

Total Due MJCJA by June 30th, 2021	\$ 500.00
--	------------------

Please make checks payable to:
Mississippi Justice Court Judges Association (MJCJA), and include 2021 Summer Convention and judge's name on the memo line.

Remit to: *Hon. Jason Thornton*
MJCJA Convention Chairman
9205 Rock Hill Road
Vanceleave, MS 39565

The above fee must be submitted to MJCJA by: June 30, 2021

Please attach a copy of this invoice to the check when mailed. Thank you!

EXHIBIT G

[

[

[



CLAY COUNTY PROSECUTOR

POST OFFICE BOX 835
WEST POINT, MS 39773
Telephone: (662) 494-5184
Facsimile: (662) 494-4836
Telephone: (662) 494-6140
<http://www.claycountymiss.com>
Email: michelledeasterling@gmail.com

Clay County Prosecutor
Michelle D. Easterling

June 23, 2021

Clay County Board of Supervisors
c/o Hon. Amy G. Berry, Chancery Clerk
Via Hand Delivery

RE: Purchase Request for Office of Clay County Prosecuting Attorney

Gentlemen:

I am formally requesting that the County authorize the purchase of three (3) licenses for Drop Box – Business, a cloud-based software, in order to allow Clay County to timely and efficiently provide video, audio and written discovery to defense attorneys as required by the Mississippi Rules of Criminal Procedure, Rule 17.10. I have attached a copy of Rule 17.10 herein, which requires that the State provide copies of audio and/or video recordings, witness statements, incident reports, and related materials upon written request by the defense attorney.

I am also attaching a copy of my current discovery log for Clay County Justice Court, which gives you a general idea of the volume of requests I receive. In order to comply with these requests, I send copies of motion to law enforcement agencies, and they in turn will conduct a search of all relevant matters, secure all written reports, witness statements, and photographs and locate and download all video and/or audio files. Then, copies of all such materials must be made in duplicate, for both the State and the defense. Due to the size of the video files, it takes a significant amount of time to burn the videos to discs for production to the other side. Also, a disk only holds 4.27 GB of information and when there are multiple officers' cameras involved, or when the stop is lengthy, as in a DUI arrest, the video can take up multiple DVDs, which again need to be burned in order to create the duplicate copy.

Drop Box makes file sharing of these kinds of materials much easier and less time consuming as it is generally done with the click of a few keys. Links to the Drop Box files are shared with the requesting defense attorneys and they can access the files upon invitation. Then, it becomes their problem to find a way to download the information to the right sized media.

I have attached a printout from the Drop Box website for your review. The most important feature is the amount of space – the size of items being uploaded. I think that if we had at least two licenses, one for me and one for the Sheriff's Office, we could handle these requests much more efficiently, with much less effort. A third license could be for use by the Highway Patrol, in order to allow their troopers to upload their dash camera footage and incident reports and materials. Getting three licenses affords us the best price, \$12.50 per user, with a minimum of 3 users. The total cost for this service – less than \$500.00 per year – is quite reasonable when one factors in the time that will be saved by law enforcement personnel in procuring the materials.

If you would like for me to answer any questions, I will be glad to.

Thank you for all you do to support the Office of the County Prosecutor and our Law Enforcement Officers.

Very truly yours,

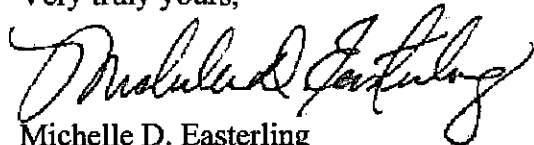

Michelle D. Easterling

Enclosures

c: Sheriff Eddie Scott
Capt. Larry Conn, MHP G Troop

JX



Statutes, codes, and regulations

Mississippi Court Rules

Mississippi Rules of ...

Rule 17 - Disclosure ...

Miss. R. Crim. P. 17.10

[Download](#)

As amended through August 11, 2020

Rule 17.10 - Discovery in Municipal and Justice Courts

(a) Discovery by the Defense. Upon written request made prior to trial, the prosecuting attorney shall provide to the defense the following:

- (1) the names of all witnesses expected to testify for the prosecution;
- (2) a copy of any written statement of the defendant;
- (3) a copy of the criminal record of the defendant, if proposed for use as impeachment;
- (4) a copy of laboratory reports or reports of any tests made;
- (5) any physical evidence, photographs, and/or electronic data to be offered in evidence;
- (6) a copy of any exculpatory material concerning the defendant; and
- (7) any affidavit used to obtain a search warrant in the case.

The prosecutor has a continuing duty to supplement any disclosure previously furnished.

(b) Reciprocal Discovery. The prosecuting attorney is entitled to reciprocal discovery of items (a)(1) - (7).

CLAY COUNTY JUSTICE COURT DISCOVERY LOG

<u>NAME OF DEFENDANT</u>	<u>NATURE OF CHARGE</u>	<u>AGENCY & BADGE NO.</u>	<u>DEFENSE ATTORNEY</u>	<u>REQUEST RECEIVED</u>	<u>REQUEST SENT TO LEA</u>	<u>DISCOVERY RECEIVED</u>	<u>DISCOVERY SENT TO ATTY</u>	<u>TRIAL DATE</u>
Brown, John A.	DUI	MHP/G33	Cliett, Mark	2/3/2021	2/4/2021	2/12/2021	5/20/2021	7/15/2021
Brown, Zachary	DUI	MHP/G36	Roberson, Rob	10/28/2020	10/28/2020	11/1/2020	11/1/2020	7/29/2021
Cannon, Michael	DUI	CCSO/C15	Cliett, Mark	4/16/2021	5/20/2021			6/24/2021
Clay, Terry		CCSO	Jones, Bennie	4/14/2021	5/20/2021	6/15/2021	6/15/2021	6/24/2021
Dean, Jason	Felony	CCSO	Jones, Bennie	1/12/2021	N/A	N/A	N/A	N/A
Deloach, Dennis	DUI	MHP/G33, G14 Stins	Adams, Steven	5/21/2021	6/10/2021			7/29/2021
Farmer, Tony		MHP/G33	Cliett, Mark	5/18/2021	5/18/2021	5/20/2021	5/20/2021	7/15/2021
Gibson, Tyvoris	Felony	CCSO/C3	Harris, Clarissa	10/1/2020	N/A	N/A	N/A	N/A
Logan, Derrnell	DUI	MHP/G33	Cliett, Mark	5/12/2021	5/12/2021	5/20/2021	5/20/2021	7/15/2021
Poole, Jon Curtis		CCSO/C4,C21,C9	Jones, Bennie	2/19/2020	2/19/2020	7/17&25/2020 & 6/15/2021	7/17&25/2020 & 6/17/2021	6/24/2021
Sease, Brian		MHP/G51, G12	Vollar, Austin	4/12/2021	6/10/2021			7/15/2021
Singh, Harpeit		T7 (P.Butler)	Jones, Bennie	4/8/2021	6/10/2021	6/22/2021	6/23/2021	6/24/2021
Smith, James	DUI	MHP/G;C9, C12	Ford, Angela T.	8/6/2020	8/12/2020	12/15/2020 (P)	5/14/2021	TBD
Todd, Adam	Felony	CCSO/C6	Ray, Rod	3/11/2021	N/A	N/A	N/A	N/A
White, Taggart	DUI	MHP/G33, G16	Cliett, Mark	5/13/2021	5/20/2021	6/21/2021	6/21/2021	6/24/2021

267

Choose the right Dropbox for you

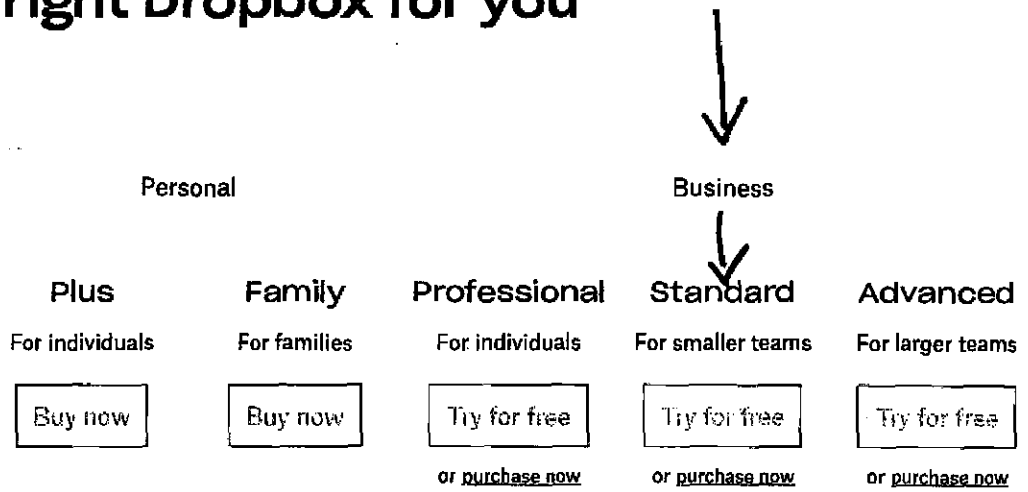

Dropbox core features

	Plus	Family	Professional	Standard	Advanced
Storage	2 TB (2,000 GB)	Share 2 TB (2,000 GB)	3 TB (3,000 GB)	5 TB (5,000 GB)	As much space as needed
Users	1 user	Up to 6 users	1 user	3+ users	3+ users
Best-in-class sync technology	✓	✓	✓	✓	✓
Anytime, anywhere access	✓	✓	✓	✓	✓
Computer backup	✓	✓	✓	✓	✓
Easy and secure sharing	✓	✓	✓	✓	✓
256-bit AES and SSL/TLS encryption	✓	✓	✓	✓	✓

Content and accident protection

	Plus	Family	Professional	Standard	Advanced
File recovery and version history	30 days	30 days	180 days	180 days	180 days
Dropbox Rewind	30-day history	30-day history	180-day history	180-day history	180-day history
Remote device wipe	✓	✓	✓	✓	✓
Enable two-factor	✓	✓	✓	✓	✓



Dropbox Passwords

Dropbox Vault

Document Watermarking

Shared link controls

Account transfer tool

Enables HIPAA compliance

Device approvals

Productivity and sharing tools

Family Room

Dropbox Paper

Dropbox Transfer

HelloSign eSignatures

File locking

Integrated cloud content

Branded sharing

Traffic and insights

Web previews and comments

Plus button

File requests

Smart Sync

Smart Sync Auto-

Dropbox Passwords	✓	✓	✓	✓	✓
Dropbox Vault	✓	✓	✓	✓	✓
Document Watermarking			✓	✓	✓
Shared link controls			✓	✓	✓
Account transfer tool				✓	✓
Enables HIPAA compliance				✓	✓
Device approvals					✓

Family Room		✓			
Dropbox Paper	✓	✓	✓	✓	✓
Dropbox Transfer	Send up to 2 GB per Transfer	Send up to 2 GB per Transfer	Send up to 100 GB per Transfer, including customization options	Send up to 2 GB per Transfer	Send up to 100 GB per Transfer, including customization options
HelloSign eSignatures	Send up to 3 documents for eSignature per month	Send up to 3 documents for eSignature per month	Send up to 3 documents for eSignature per month	Send up to 3 documents for eSignature per month	Send up to 3 documents for eSignature per month
File locking			✓	✓	✓
Integrated cloud content	✓	✓	✓	✓	✓
Branded sharing			✓	✓	✓
Traffic and insights			✓		✓
Web previews and comments	✓	✓	✓	✓	✓
Plus button	✓	✓	✓	✓	✓
File requests	✓	✓	✓	✓	✓
Smart Sync	✓	✓	✓	✓	✓
Smart Sync Auto-	✓	✓	✓	✓	✓

Full text search

Viewer history

Team management

Admin console

Multi-team admin login

Centralized billing

Company-managed groups

Unlimited API access to security platform partners

Unlimited API access to productivity platform partners

1 billion API calls/month for data transport partners

Tiered admin roles

Sign in as user

Audit logs with file event tracking

Single sign-on (SSO) integrations

Invite enforcement

Support

Priority email support

Live chat support

Phone support during business hours

Full text search	✓	✓	✓	✓	✓
Viewer history			✓		✓
Team management					
Admin console				✓	✓
Multi-team admin login				✓	✓
Centralized billing		✓		✓	✓
Company-managed groups				✓	✓
Unlimited API access to security platform partners				✓	✓
Unlimited API access to productivity platform partners				✓	✓
1 billion API calls/month for data transport partners				✓	✓
Tiered admin roles					✓
Sign in as user					✓
Audit logs with file event tracking					✓
Single sign-on (SSO) integrations					✓
Invite enforcement					✓
Support					
Priority email support	✓	✓	✓	✓	✓
Live chat support			✓	✓	✓
Phone support during business hours				✓	✓



- Billed yearly
- Billed monthly

\$9.99 / month

Buy now

\$16.99 / month

Buy now

\$16.58 / month

Try for free
or [purchase now](#)

\$12.50 / user / month

Try for free
or [purchase now](#)

\$20 / user / month

Try for free
or [purchase now](#)



Dropbox

- Desktop app
- Mobile apps
- Plans
- Security
- Features

Products

- Plus
- Family
- Professional
- Business
- Enterprise
- HelloSign

Company

- About us
- Jobs
- Press
- Investor relations
- Blog

Support

- Help center
- Contact us
- Cookies
- Privacy & terms
- Sitemap

Community

- Developers
- Referrals
- Forum

$$\begin{array}{r}
 12.50 \\
 \times 3 \\
 \hline
 37.50 \\
 \times 12 \\
 \hline
 \$ 450.00 \\
 \text{annually}
 \end{array}$$

English (United States)

EXHIBIT H

7

7

7



2717 Mattox Street

Tupelo, MS 38801
 (662) 842-0234 Fax: (662) 680-4966



MOTOROLA SOLUTIONS
QUOTATION

QUOTE NO.: 25205 - 00 EC
 DATE: 7/01/21
 TERMS: NET DUE
 DELIVERY: UPS

14305
 TO: CLAY COUNTY SHERIFF
 Anthony Cummings
 PO BOX 142
 WEST POINT, MS 39773

Please reference Quote No. on
 Correspondence & purchase orders.
 Prices firm for 30 days.

WE ARE PLEASED TO QUOTE YOU THE FOLLOWING:

QTY	DESCRIPTION	UNIT PRICE	DISC	TOTAL
8	FRONT MOUNT INSTALL	95.00		760.00
8	MOBILE HIGH POWER CABLE	25.00		200.00
8	30' NMO COAX MOUNT	25.00		200.00
3	TRIP CHARGE	50.00		150.00
8	MINI UHF CONNECTOR	6.00		48.00
AN UPCHARGE OF 2% MC/V/DIS OF GROSS SALES BE ADDED				
WE ARE GOING GREEN WITH PAPERLESS INVOICES				
Installation of 8 APX1500 mobile radios into 2021				
Dodge Durangos. Radios, Mounting brackets and		Item Summary		1,358.00
Antennas pulled from old vehicles by Clay Co.		Subtotal		1,358.00
Sheriff's Dept.		Sales Tax		.00
		Grand Total		1,358.00

ORDERS SUBJECT TO SHIPPING & HANDLING AND SALES TAX IF APPLICABLE

TERMS SUBJECT TO CREDIT REVIEW

BY NEIL CRONE (000)000-0000 Ext

Accepted by _____ P.O. No. _____
 LEGAL NAME OF PURCHASER

 AUTHORIZED SIGNATURE Date _____

EXHIBIT I

All Invoices are due on the 10th of each month, following purchase. All past due accounts will be subject to a 1.5% service charge.

Thank You

Bill To: CLAY COUNTY BOARD OF SUPERVISOR
205 COURT STREET
P. O. BOX 815
WEST POINT MS 39773

662-494-3124
Ship To: CLAY COUNTY BOARD OF SUPERVISOR
205 COURT STREET
P. O. BOX 815
WEST POINT MS 39773

Invoice#	Order#	Customer#	Customer P.O.#	Terms	Salesperson
06/11/21	455207	CLAY		NET 10TH PROX	HOU
Units	U/M	Item Description	Disc	Unit Price	Amount
		***** QUOTATION *****			
1	EA	GSZ140601 5 TON HEAT PUMP 14 SEER UNIT R410A		2242.000	2,242.00
1	EA	HPC-103-S 3/8" SPORLAN CATCH- ALL HEAT PUMP DRIER SWEAT 1-5 TONS		27.000	27.00
		Subtotal			2,269.00
		Quote Total			2,269.00

PAYMENT OPTIONS: Cash, Check, ACH Bank Draft, MasterCard, Visa, American Express, Mail
1600 Gardner Blvd, P.O. Box 2522 Columbus, MS 39702 www.refrigerationsupplyofcolumbus.com

EXHIBIT J

]

]

]

2 Upper Control Arms
Special (Adjustable) @ 240 480

[2 Lower Ball Joints @ 40 80

2 Lower Control Arms
(Forward) @ 125 250

2 Lower Control Arms
(Rearward) @ 100 200

2 Sway Bar Links @ 40 80

2 Sway Bar Bushing @ 20 40

6 Hours Labor 480

4 Wheel Align 20

[1680^m

2 Tires @ 140 280

\$1,960.00

C-24

2016 Charger

Dodge / Ram / SRT : Charger : 2017-18 : Rear Wheel Drive : Police

Current Measurements

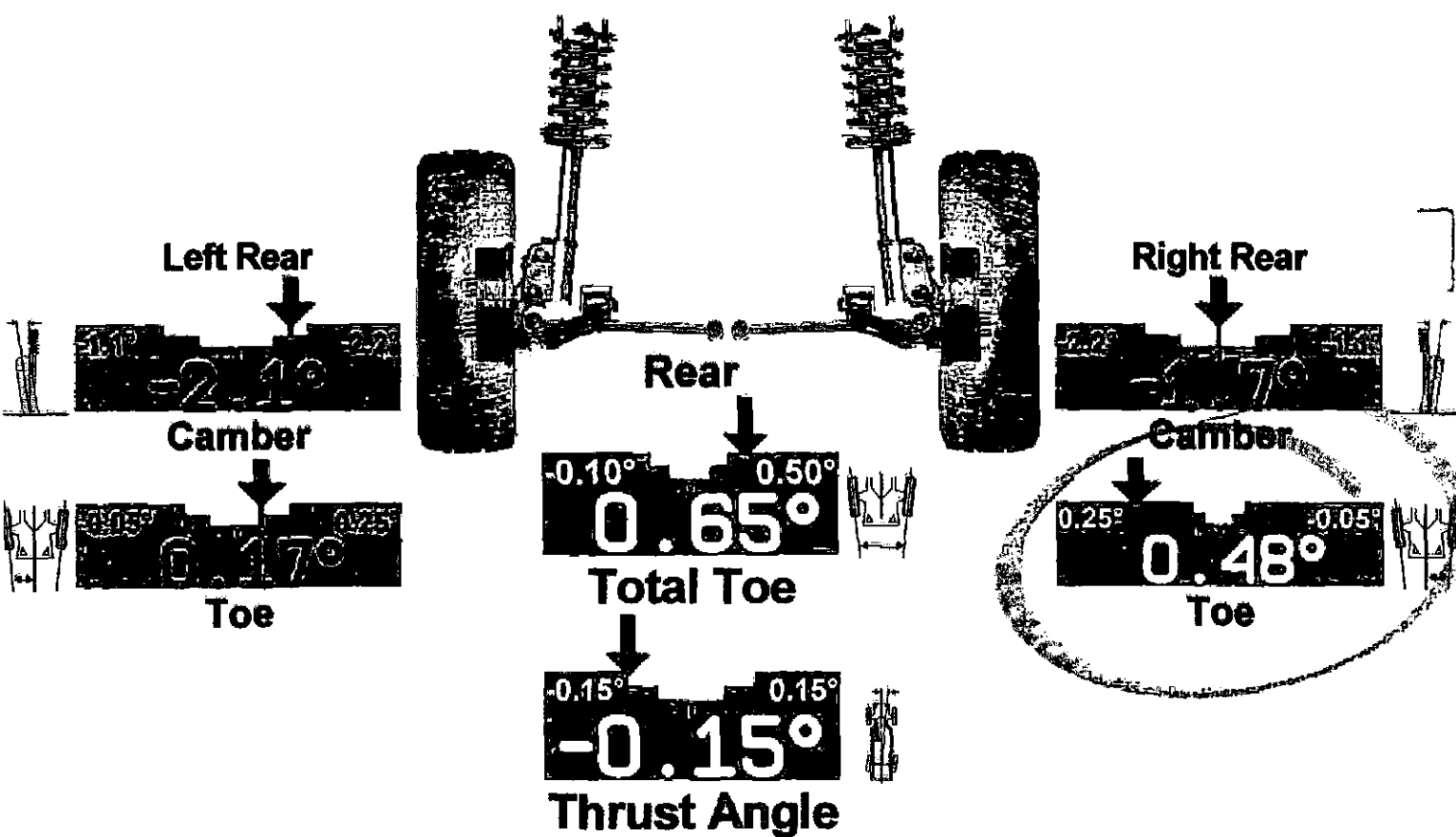
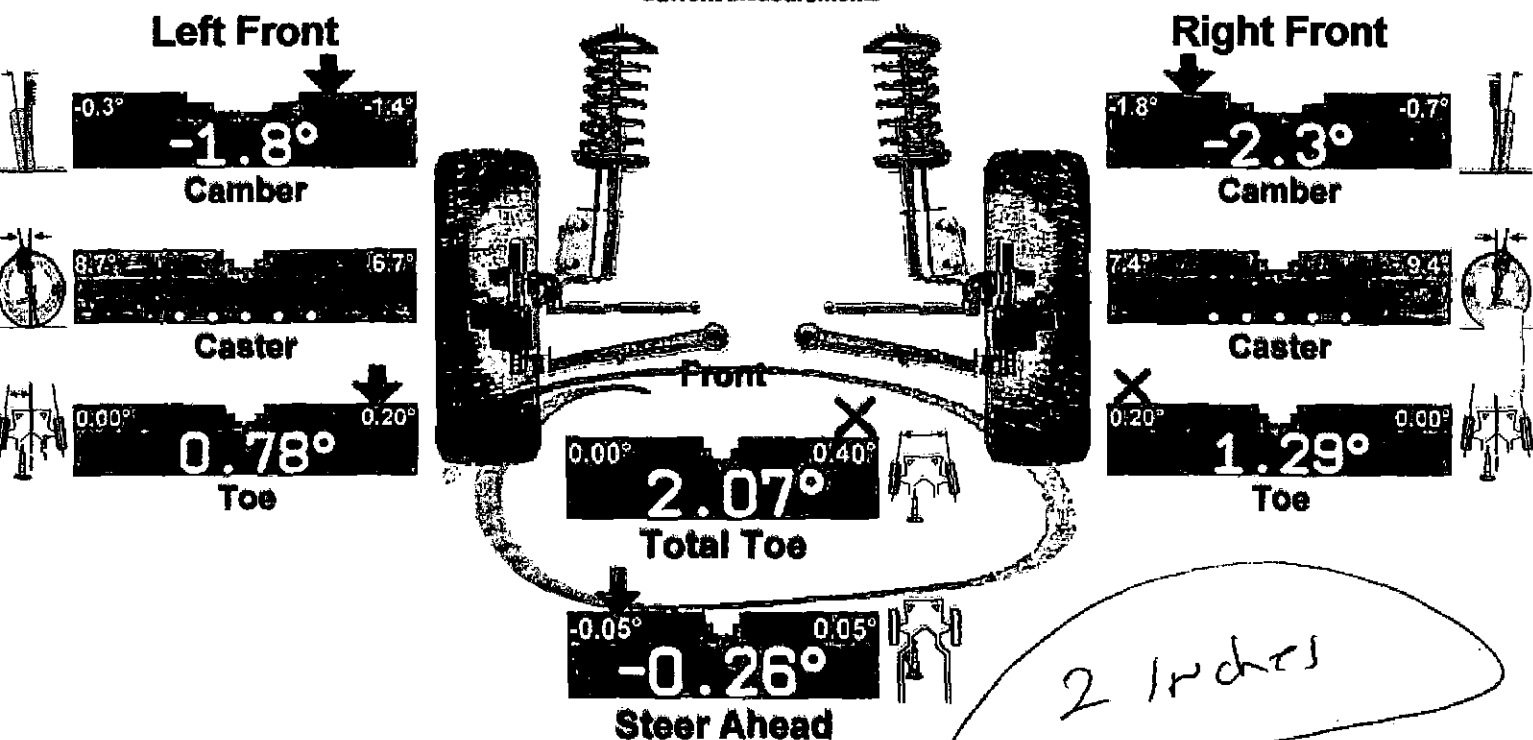

• One or more values are not within specification. Tire wear, handling and safety problems may result.

EXHIBIT K

Scales Biological Laboratory, Inc.

INVOICE

220 Woodgate Dr. S.
Brandon, MS 39042
Phone (601) 825-3211
Fax: (601) 825-1411
E-mail: scalesbio@aol.com



DATE: June 24, 2021
INVOICE # 8545

TAX ID: 64-0795678

JUN 28 2021

Bill To:
Clay County Sheriff's Office
P.O. Box 142
West Point, MS 39773

For:
CCSO Case # 21-009
SBL Case # 2-3-21-8545

Attn: Debbie Ingram
E-mail: dingramccso@yahoo.com

DESCRIPTION	UNITS	RATE	AMOUNT
Screening evidence	3.67 hrs.	\$250/hr.	\$ 917.50
Analysis for the presence of blood	1 sample	\$250/sample	250.00
Autosomal STR DNA analysis	10 samples	\$500/sample	5,000.00
TOTAL DUE			\$6,167.50



If necessary, please contact Inv. Jeremy Dubois regarding this invoice. Thank you.

Payment is due within 30 days of receipt.

Make all checks payable to **Scales Biological Laboratory, Inc.**, note invoice number on check, and send to the address above.

EXHIBIT L

[

[

[



AUTO PARTS

STORE

600007632
JIM'S AUTO PARTS, INC.
7008 Hwy 45 Alt North
(662)494-4541
West Point, MS 39773-9442
(662) 494-4541

Time: 07:08 Date: 05/28/2021 Page: 1/1

Employee: 1 , Milton
Sales Rep: 0 , Salesman
Accounting Day: 23

SOLD TO 1415
CLAY CO, SANITATION 112
P O Box 815
West Point, MS 39773

Anticipated Time:
Attention:
Tax Exemption:
PO#:
Terms: Net 10th nsc

981	NCB	Xtreme Klean 22 OZ	2.00	0.00	10.9900	21.98
75130	NPP	TOWELS	1.00	6.18	2.4900	2.49
		Above Item on Sale				
763-1300	BK	GR MNKY GRL GRP GLOVE	1.00	10.24	5.2900	5.29
763-1301	BK	GR MNKY GRL GRP GLOVE	1.00	10.24	5.2900	5.29

Not called

Customer Signature
ALL GOODS RETURNED MUST BE ACCOMPANIED BY THIS INVOICE

CUSTOMER COPY

Subtotal	35.05
7.0 TAX TABLE 7.0000%	0.00
Charge Sale	35.05

725025
Invoice Number

Add Timmy?

282



AUTO PARTS

STORE

600007632
JIM'S AUTO PARTS, INC.
7008 Hwy 45 Alt North
(662)494-4541
West Point, MS 39773-9442
(662) 494-4541

Time:10:36 Date:06/10/2021 Page: 1/1

Employee: 5 , Doug
Sales Rep: 0 , Salesman
Accounting Day: 9

SOLD TO
1415
CLAY CO, SANITATION 112
P O Box 815
West Point, MS 39773

Anticipated Time:
Attention:
Tax Exemption:
PO#:
Terms: Net 10th nsc

Part Number	Qty	Description	Unit Price	Price	Net	Total
981	NCB	Xtreme Kleen 22 OZ	2.00	0.00	10.9900	21.98

Notal Hain

Customer Signature

ALL GOODS RETURNED MUST BE ACCOMPANIED BY THIS INVOICE

DUPLICATE

Subtotal	21.98
7.0 TAX TABLE 7.0000%	0.00
Total	21.98
Charge Sale	21.98

Invoice Number 725889

283



AUTO PARTS

SCORE

600007632
JIM'S AUTO PARTS, INC.
7008 Hwy 45 Alt North
(662)494-4541
West Point, MS 39773-9442
(662) 494-4541

Time: 15:20 Date: 06/14/2021 Page: 1/1

Employee: 2 , Bill
Sales Rep: 0 , Salesman
Accounting Day: 12

1415
CLAY CO. SANITATION 112
P O Box 815
West Point, MS 39773
Anticipated Time:
Attention:
Tax Exemption:
PO#:
Terms: Net 10th nsc

981	NCB	Xtreme Kleen 22 Oz	2.00	0.00	10.9900	21.98
75130	NPP	TOWELS	2.00	6.18	2.4900	4.98
		Above Item on Sale				

Customer Signature
Customer Signature
ALL GOODS RETURNED MUST BE ACCOMPANIED BY THIS INVOICE
CUSTOMER COPY

Subtotal	26.96
7.0 TAX TABLE 7.0000%	0.00
Charge Sale	26.96

Invoice Number: 726184

284



AUTO PARTS

STORE

600007632
JIM'S AUTO PARTS, INC.
7008 Hwy 45 Alt North
(662)494-4541
West Point, MS 39773-9442
(662) 494-4541

Time: 07:08 Date: 06/18/2021 Page: 1/1

Employee: 5 , Doug
Sales Rep: 0 , Salesman
Accounting Day: 16

SOLD TO
1415
CLAY CO, SANITATION 112
P O Box 815
West Point, MS 39773

Anticipated Time:
Attention:
Tax Exemption:
PO#:
Terms: Net 10th nsc

Part Number	Units	Description	Quantity	Price	Net	Total
763-1341	BK	GM 3 PACK UTILITY XL Above Item on Sale	1.00	18.50	9.9900	9.99

Customer Signature

Customer Signature

ALL GOODS RETURNED MUST BE ACCOMPANIED BY THIS INVOICE

Subtotal 9.99
7.0 TAX TABLE 7.0000% 0.00

Total 9.99

Charge Sale 9.99

Invoice Number 726522

DUPLICATE

285



AUTO PARTS

STORE

600007632
JIM'S AUTO PARTS, INC.
7008 Hwy 45 Alt North
(662)494-4541
West Point, MS 39773-9442
(662) 494-4541

Time: 07:18 Date: 06/24/2021 Page: 1/1

Employee: 7 , John
Sales Rep: 0 , Salesman
Accounting Day: 21

SOLD TO 1415
CLAY CO, SANITATION 112
P O Box 815
West Point, MS 39773

Anticipated Time:
Attention:
Tax Exemption:
PO#:
Terms: Net 10th nsc

763-1340	BK	GM 3 PACK UTILITY L Above Item on Sale	2.00	18.50	9.9900	19.98
----------	----	---	------	-------	--------	-------

Curtis Smith

CUSTOMER UNLESS
ALL GOODS RETURNED MUST BE ACCOMPANIED BY THIS INVOICE

Subtotal	19.98
7.0 TAX TABLE 7.0000%	0.00
Charge Sale	19.98

INVOICE NUMBER 726921

286



AUTO PARTS

600007632
JIM'S AUTO PARTS, INC.
7008 Hwy 45 Alt North
(662) 494-4541
West Point, MS 39773-9442
(662) 494-4541

Time: 12:14 Date: 06/24/2021 Page: 1/1

Employee: 5 , Doug
Sales Rep: 0 , Salesman
Accounting Day: 21

SOLD TO
1410
Clay County Board of Supervisors
P O Box 815
West Point, MS 39773
Anticipated Time:
Attention:
Tax Exemption:
PO#:
Terms: Net 10th nsc

Part Number	Description	Quantity	Price	Net	Total
AR153SB	MPE RELAY	1.00	33.87	18.4900	18.49

Jimmy M...
Customer Signature
ALL GOODS RETURNED MUST BE ACCOMPANIED BY THIS INVOICE

Subtotal	18.49
7.0 TAX TABLE 7.0000%	0.00
Total	18.49
Charge Sale	18.49

726958
Invoice Number

DUPLICATE

287



STORE

600007632
JIM'S AUTO PARTS, INC.
7008 Hwy 45 Alt North
(662)494-4541
West Point, MS 39773-9442
(662) 494-4541

Time: 11:57 Date: 06/22/2021 Page: 1/1

Employee: 1 , Milton
Sales Rep: 0 , Salesman
Accounting Day: 19

SOLD TO

1410
Clay County Board of Supervisors
P O Box 815
West Point, MS 39773

Anticipated Time:
Attention:
Tax Exemption:
PO#:
Terms: Net 10th nsc

735-5172	NOE	2004 Chevrolet Truck Silverado 1500 1/2 Ton 2WD - P				
134A	NFR	Door Handle - Exterior	1.00	47.29	42.9900	42.99
6564	NFR	120Z 134A	1.00	19.99	5.9900	5.99
	NFR	stop leak	1.00	0.00	5.9900	5.99

Jim Milton
Customer Signature

ALL GOODS RETURNED MUST BE ACCOMPANIED BY THIS INVOICE

Subtotal	54.97
7.0 TAX TABLE 7.0000%	0.00
Charge Sale	54.97

Invoice Number 726774

EXHIBIT M



4-County Foundation Apply Now

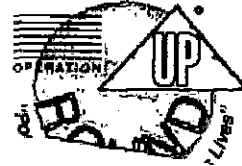
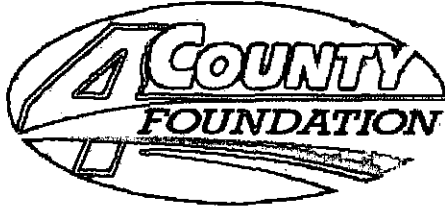

Groups or Organizations

Groups and Organizations can return an application with appropriate documents including financial documentation, and itemized request list including estimates, bids or actual pricing. Organizations awards are capped at \$10,000.

Individuals

Individuals are eligible to make an application for catastrophic intervention. Awards are capped at \$

All applications may be returned by mail to:

4-County, ATTN Foundation, PO Box 351, Columbus, MS 39703

or scan and email to 4CountyFoundation@4county.org; or can be dropped off at our Starkville office at 9776 Frontage Rd. Columbus during normal business hours.

Organizing Application

Individual Application

Guidelines

*Get approval from Board of Supervisors please
-Cynthia Wilson*

Starkville Office
9776 Frontage Rd.
Columbus, MS 39703

Corporate Center
400 Northline Street
Columbus, MS 39703

(800) 431-4304



(800) 431-4304

Corporate Center
400 Northline Street
Columbus, MS 39703

Starkville Office
9776 Frontage Rd.
Columbus, MS 39703





4-County Foundation Guidelines

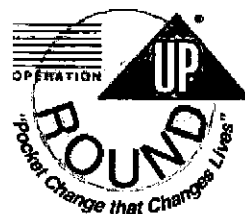

Contribution Guidelines for 4-County Foundation, Inc.

I. The objective of 4-County Foundation, Inc. (the Foundation) is to provide assistance to area organizations and projects whose primary purpose is an improvement in the quality of life for residents in the service territory of 4-County Electric Power Association.

II. Our goals are to address the needs of our service area, to designate available dollars where we can optimize our impact and to provide cost effective assistance to worthwhile organizations and projects with local significance.

III. Board of Director Guidelines:

A. Contributions are generally made in the following categories:

1. Health and Human Services
2. Education
3. Catastrophic Intervention

B. All requests to the Foundation must be made in writing and may merit a formal presentation before the Board.

C. Grants are intended for capital programs and special needs and not for on-going operational expenses.

IV. Exclusions:

A. Grants are not made to organizations that discriminate based on race, color, religion, gender, disability, age, genetics or national origin.

B. The Foundation cannot make unrestricted grants to churches and religious organizations. However, requests for church-affiliated hospitals, schools, community outreach programs or charitable programs will be considered if the sponsoring church meets the requirements of 501(c).

C. The Foundation cannot make grants to lobbying groups or political causes.

D. The Foundation cannot make grants for the payment of electric bills.

E. The Foundation cannot make grants to its Board of Directors or their close relatives, to the 4-County Electric Power Association Board of Directors or their close relatives, or to 4-County Electric Power Association employees or their close relatives (see Article XVIII of Bylaws).

V. Administration of Corporate Contributions:

A. Dollars are distributed to tax exempt organizations as defined under Section 501(c) of the Internal Revenue Code, or organizations with a similar tax exempt status of the Internal Revenue Code, and are providing services or operating within the area served by 4-County Electric Power Association.

B. Distributions on all amounts require the Board of Directors approval and shall be limited to a maximum of \$10,000 annually. Distributions exceeding \$10,000 require two-thirds (2/3) vote of the entire Board(s). Distributions to Individuals shall not exceed \$2,500 annually. Emergency expenditures not to exceed \$2,500, require the vote of at least 3 Members of the Executive Committee and must be disclosed to the full Board at its next meeting. In addition to a written proposal on the application provided by the Foundation, the request for a donation must include the organization's fiscal year budget.

C. If an organization has various subsidiaries, each branch/location is to be considered separate even though they may operate under the umbrella of one 501(c) or similar IRS exemption. Example: New Hope High School and West Lowndes High School operate under the Lowndes County School District. However, each school should be treated as a separate entity.

D. Contributions will be evaluated in three categories: (1) health and human services, (2) education and (3) catastrophic intervention.

[Apply Now](#)

[Get Help](#)



4-County Foundation, INC. Application for Organization



The 4-County Foundation was formed to give back to our members and the communities in which they live and work. Funds are distributed to tax exempt organizations as defined under Section 501(c) of the Internal Revenue Code and which are providing services or operating within the area served by 4-County Electric Power Association.

The Foundation Board of Directors meets approximately every two months to consider applications (subject to change). Applications must be received by the end of the month prior to the next scheduled board meeting. For example, applications for a January meeting must be received by 4-County no later than December 31. Applications received after the deadline will be held until the next board meeting.

Applications may be sent electronically to 4countyfoundation@4county.org, mailed to 4-County Foundation, PO Box 351, Columbus, MS 39703, or delivered to one of our offices.

Our goal is to support every eligible entity, but we cannot consider incomplete applications. This checklist will help make sure your organization's application has all the necessary items required for consideration. Please be as specific as possible in the information provided. If you have questions, please contact us at 4countyfoundation@4county.org or call at 662-327-8900.

Requirements

The following must be included in application package to be considered complete:

- 501(c) Exemption letter from IRS
- Tax ID/EIN number
- Current Audited Financial Statement for Organization or IRS Form 990. If an audited financial is not available, attach detailed statement showing revenue, sources of revenue, program expenditures and cash/assets on hand
- Information on how grant funds will be used along with sources and uses of existing program funds, and itemized requests including quotes from vendors or pricing from retailers and total amount of Foundation grant requested. Special emphasis will be placed on benefit to 4-County members.
- All questions must be answered (please include additional pages if needed)
- Application must be signed.

Applications will be evaluated on several factors including:

- Potential benefit to residents/communities in 4-County service territory, with special emphasis on impact to 4-County members
- Whether person making application is a 4-County member and participates in Operation Roundup®
- Results that are predictable and can be evaluated
- Examples of funding sources for your project other than the 4-County Foundation
- Proper documentation and post grant reporting for organizations who have received a prior Foundation award

If the space provided for answers is not enough, please feel free to add additional pages. The more detail, the better for the Foundation Board when considering applications. *Incomplete applications will not be accepted.*

- Complete Legal Name of
1. Organization/Agency: _____
Official name of org/agency & must match name associated with Tax ID (line #7)
2. Address: _____
Street Address (include Post Office Box, if applicable)
- _____
- City or Town** _____ **State** _____ **Zip Code** _____
3. Phone Number: _____
Office _____ **Cell** _____
4. Contact Person: _____
Name _____ **Title** _____
5. Contact Email: _____
6. Is the person completing this application a member of 4-County Electric Power Association? _____
a. If so, are you participating in the Operation Round Up® program? _____
7. Tax ID Number _____
Number Assigned to Organization/Agency listed in Line #1
8. Please give a brief description of Organization/Agency's core purpose and focus (Mission Statement):

9. Has your organization received a prior grant(s) from the 4-County Foundation? If so, please list award(s) and date(s) received. (Organizations are only eligible for grants once a year) :

10. Please provide a copy of Organization's most current financial statement or IRS Form 990.
- Number of individuals, families, or groups served in each of the following counties in the last year:
11. Chickasaw _____, Choctaw _____, Clay _____, Lowndes _____, Monroe _____,
Noxubee _____, Oktibbeha _____, Webster _____, Winston _____.

2. Does organization/agency serve outside Chickasaw, Choctaw, Clay, Lowndes, Monroe, Noxubee, Oktibbeha, Webster, or Winston Counties?

Yes _____ No _____

a. If yes, please provide information on number served and location:

3. A. State the *purpose* of Organization/Agency's funding request (*explain how funds are to be used and how they benefit the Community/Area*). If Organization has sufficient resources to complete this project without Foundation aid, please explain why this grant is being requested. **Please include other sources of funding your Organization will be utilizing for this request/project:**

B. State the ***total amount*** of funding this application requests from the Foundation: \$ _____
(do not leave blank).

C. Include itemized list with pricing, including quotes. For example: "After school program support: 50 workbooks @ \$5.00 each; 50 boxes of crayons @ \$3.95 each = **\$447.50**". (Attach additional page(s) if needed.)

4. How are Organization/Agency's programs measured for effectiveness? _____

15. Please list three references:

Name Phone

Address City State Zip

Name Phone

Address City State Zip

Name Phone

Address City State Zip

The information contained in this statement is for the purpose of obtaining funding from the 4-County Foundation, Inc., on behalf of the undersigned. Each undersigned understands that the information provided herein is used in deciding to grant funding, and each undersigned represents and warrants that the information provided is true and complete and that the 4-County Foundation, Inc. may consider this statement as continuing to be true and correct until a written notice of a change is provided. The 4-County Foundation, Inc. is authorized to make all inquiries deemed necessary to verify the accuracy of the statements made herein. **In accepting this award, the undersigned authorizes the release of basic information including name and likeness in written, photographic, video or electronic form for publicity use by the 4-County Foundation, Inc. and 4-County Electric Power Association. The undersigned also agrees, when applicable, to recognizing contribution of the 4-County Foundation by using provided signage on items funded or built with Foundation grants.**

Name of Organization

Signature of Representative

Date

Please make sure that your application is complete using the checklist on the first page. Incomplete applications will NOT be considered. It is the responsibility of applicant to supply a complete application.

EXHIBIT N

12-16

AUG. 11 LIVE VIRTUAL AUG. 12-15 LIVE ON-SITE AND VIRTUAL

Patty Anthony

NASHVILLE

151ST CONGRESS OF CORRECTION

AMERICAN CORRECTIONAL ASSOCIATION  AUG. 11-15, 2021

TENTATIVE SCHEDULE OF EVENTS

Time Wednesday, Aug. 11

**NOTE: Wednesday sessions are virtual only-workshops.
There will be no on-site events on this day.**

Workshop Tracks — Prisons, Jails, Mental Health, Nurses, Physicians

9-10:30 a.m.	Workshops	Virtual-Live
10:30 a.m.-12 p.m.	Workshops	Virtual-Live
1:30-3 p.m.	Workshops	Virtual-Live
3:30-5 p.m.	Workshops	Virtual-Live

Time Thursday, Aug. 12

8:30-10 a.m.	Plenary 1 and Workshops	Onsite and Virtual-Live
10:30 a.m.-12 p.m.	Workshops	Onsite and Virtual-Live
12:15-1:45 p.m.	Health Care Special Session & Luncheon <i>The Omni, Legends Ballroom Seating is limited. Sponsored by Centurion, LLC.</i>	 centurion.
2-3:30 p.m.	Workshops	Onsite and Virtual-Live
3-4:30 p.m.	Committee on Performance-Based Standards	
3:45-5:15 p.m.	Workshops	Onsite and Virtual-Live
5:30-6:30 p.m.	Health Care Network Reception <i>The Omni, Legends Ballroom Sponsored by Correct Rx Pharmacy Services.</i>	

Continued on next page →

TENTATIVE SCHEDULE OF EVENTS

Time	Friday, Aug. 13	
8:30-10 a.m.	Workshops	Onsite and Virtual-Live
10:30 a.m.-12 p.m.	Workshops	Onsite and Virtual-Live
2-3:30 p.m.	ACA General Session <i>Sponsored by Aramark Correctional Services, Inc. and Falcon Correctional and Community Services, Inc.</i>	Onsite and Virtual-Live
3:45-6 p.m.	Exhibit Hall Open House Reception	Onsite and Virtual-Live



Time	Saturday, Aug. 14	
8 a.m.-5 p.m.	Accreditation Panel Hearings	
8:30-10 a.m.	Workshops	Onsite and Virtual-Live
10:30 a.m.-12 p.m.	Workshops	Onsite and Virtual-Live
11:30 a.m.-2:30 p.m.	Exhibit Hall Open/Sponsored Lunch	Onsite and Virtual-Live
2-4 p.m.	Board of Governors Meeting	
1:30-3 p.m.	Workshops	Onsite and Virtual-Live
3:30-5 p.m.	Workshops	Onsite and Virtual-Live

Time	Sunday, Aug. 15	
8 a.m.-5 p.m.	Accreditation Panel Hearings	
8:30-10 a.m.	Plenary 2	Onsite and Virtual-Live
10 a.m.-12 p.m.	Delegate Assembly Meeting	
10:30 a.m.-12 p.m.	Workshops	Onsite and Virtual-Live
12-2 p.m.	Exhibit Hall Open/Sponsored Lunch/ Grand Prize	Onsite and Virtual-Live
6-10 p.m.	E.R. Cass Award Banquet Ticket required. <i>Sponsored by The GEO Group, Inc. and CoreCivic</i>	



EXHIBIT O

July 2-2021

Chancery Clerk Amy Berry
Clay County Board of Supervisors

I Gertrude Gaskin am asking for your help with getting adjacent property to ours cleaned up. This property belongs to Michael Harold Craft who lives at 1545 Seed Tick Road Caledonia Miss.

The Property mentioned is located at 4275 Highway 46 - Cedar Bluff - Miss 39141 which joins my Property at 3080 Joe Myers Road Cedar Bluff Miss.

The Property is a fire hazard, an eye sore and is being used for a dump. I have snakes, rodents, rats, lizards out of the grass and clutter onto my Property.

The grass is so tall you can't see down Highway 46 to enter off of Joe Myers Road.

I have begged him for ^{over} 4 years to keep the grass cut and it has only been cut 3 times in 4 years and hasn't been cut or cleaned up

up at all this year. As a matter of fact was only at once last year.

June 30th 2021 I was mowing my yard and ran over two cotton mouth moccasins and killed them in my yard and then I ran over a snake and [her little ones on my Property below my fenced yard.

I would appreciate your help with this matter as soon as possible. My supervisor R. B. Davis can attest to this.

Sincerely
Gautreaux & Loy
Gautreaux

THIS PAGE
LEFT
BLANK
INTENTIONALLY